





AUDI		Nº de homologación Official approval number Prüfung Nr. Nº d'homologation Número de homologação
A4/ A4 AVANT 2001		
	EE0120	e9*94/20*94/20* 2597*00
	EE1120	e9*94/20*94/20* 2598*00

EE0120
e9*94/20*94/20* 2597*00

EE1120
e9*94/20*94/20*

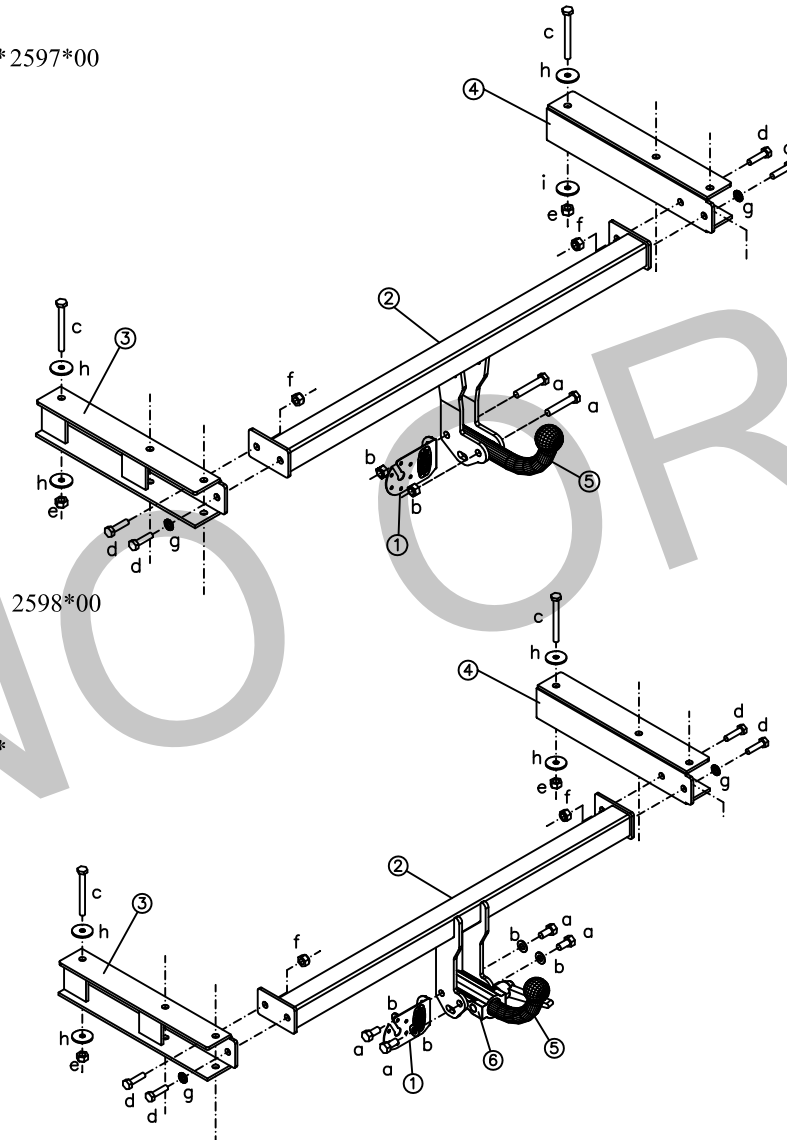
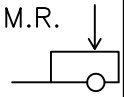













M.M.R. 	S 	D 
2000 kg.	100 kg.	10.06 kN

Par de apriete para los tornillos Tightening torque for bolts Schrauben Drehmoment Couple de serrage pour vis Par de apertado para os parafusos						
M	6	8	10	12	14	16
Nm	10	25	55	85	135	200

Enganche homologado según Directiva 94/20 CE.
Hitch officially approved in accordance with Directive 94/20 CE.
Geprüfte Kupplung gemäß Kennzeichen 94/20 CE.
Crochet homologué selon la Directive 94/20 CE.
Enganche homologado segundo directiva 94/20 CE.

**ELEMENTOS DE UNIÓN / CONNECTION COMPONENTS
DAZUGEHÖRENENDEN TEILEN / ÉLÉMENTS DE RACCORD
ELEMENTOS DE UNIÃO.**

BOLA / BALL / KUGEL BOULE/ BOLA DE REBOQUE		VEHÍCULO / VEHICLE FAHRZEUG / VÉHICULE / VEÍCULO	
			
a	 2 x M12x65 DIN 931 8.8	c	 2 x M10x100 DIN931 8.8
b	 2 x M12 DIN 985 8	d	 4 x M12x40 DIN933 8.8
		e	 2 x M10 DIN985 8
a	 4 x M12x25 DIN 933 8.8	f	 2 x M12 DIN985 8
b	 4 x M12 DIN 125 -	g	 2 x M12 DIN127 -
		h	 4 x M10 DIN9021 -

Este documento debe ser presentado en la I.T.V. junto con el certificado de montaje.
HNOS.SÁNCHEZ-LAFUENTE,S.A. no asume ningún tipo de responsabilidad por daños causados por usos inadecuados.

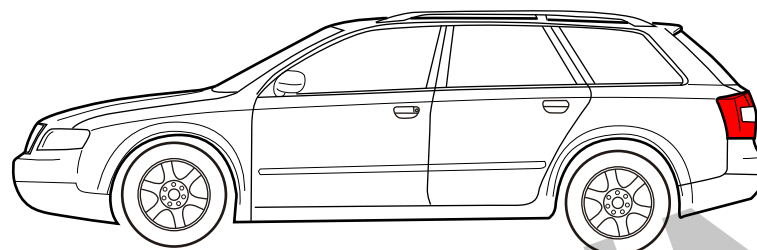
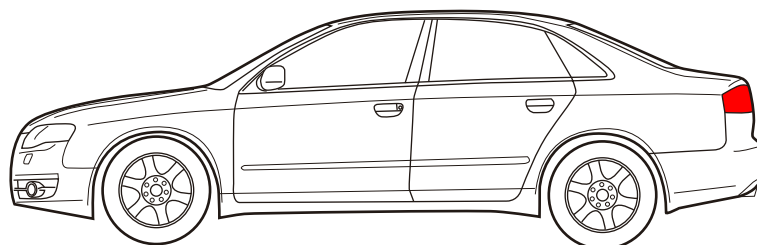

EE0120



EE1120

AUDI A4

Instrucciones de montaje - Installation instructions - Notice de montage - Montage- og driftsvejledning

1

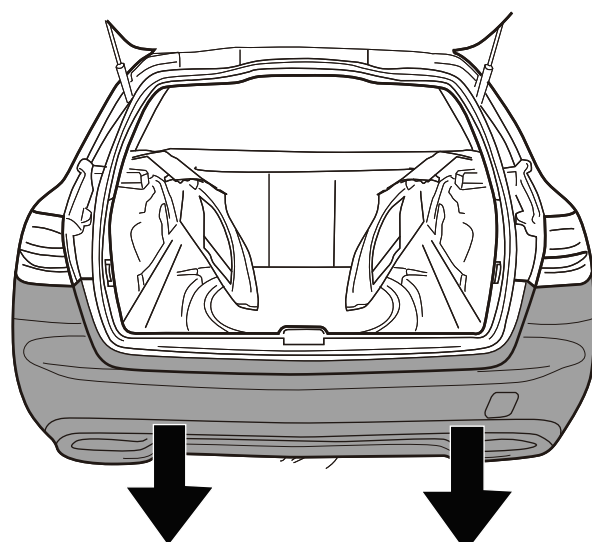
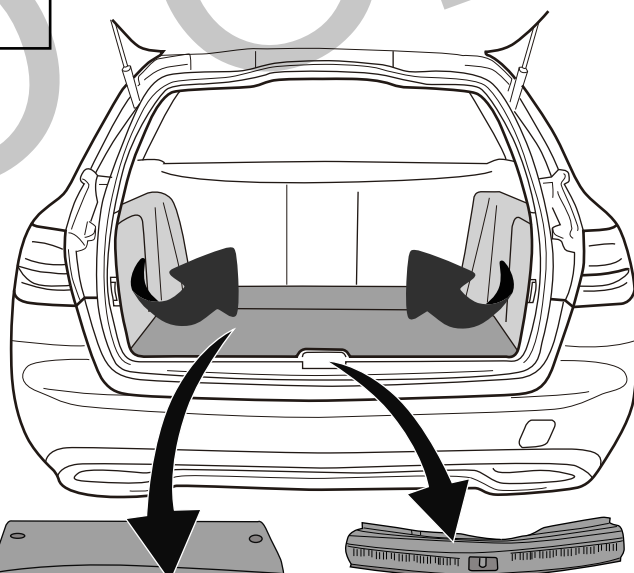

2

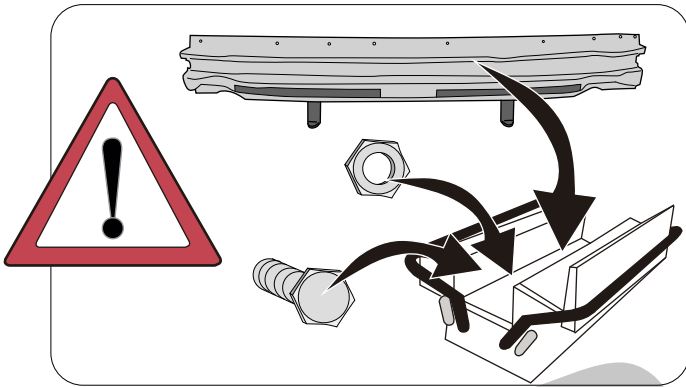
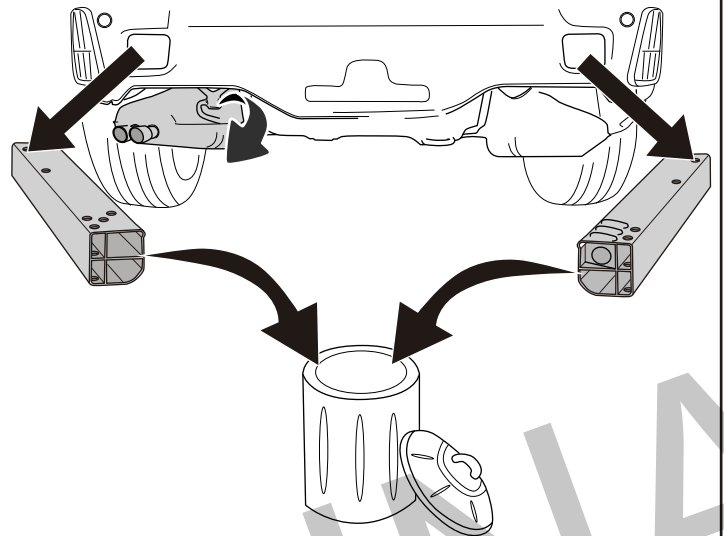
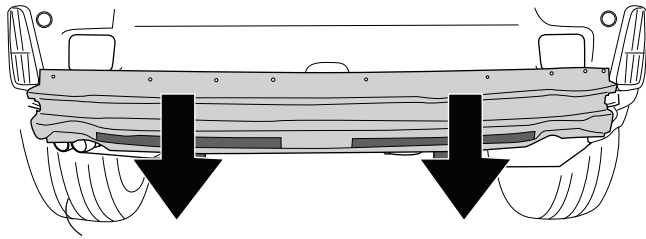

3

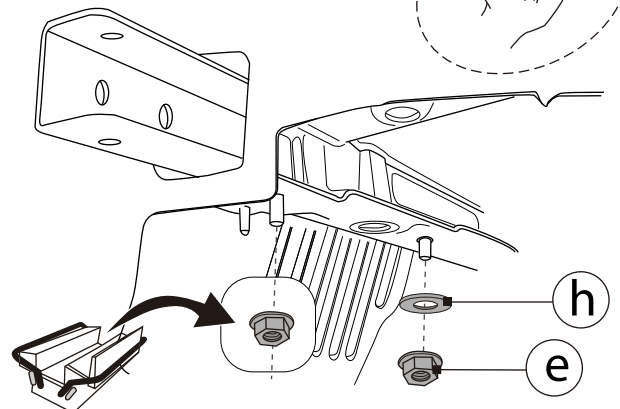
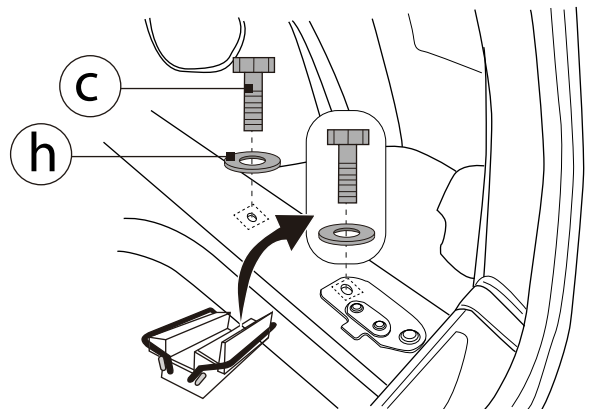
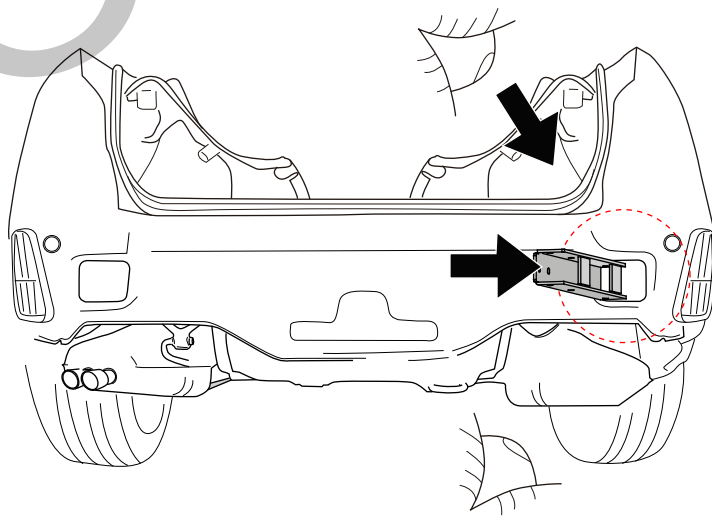

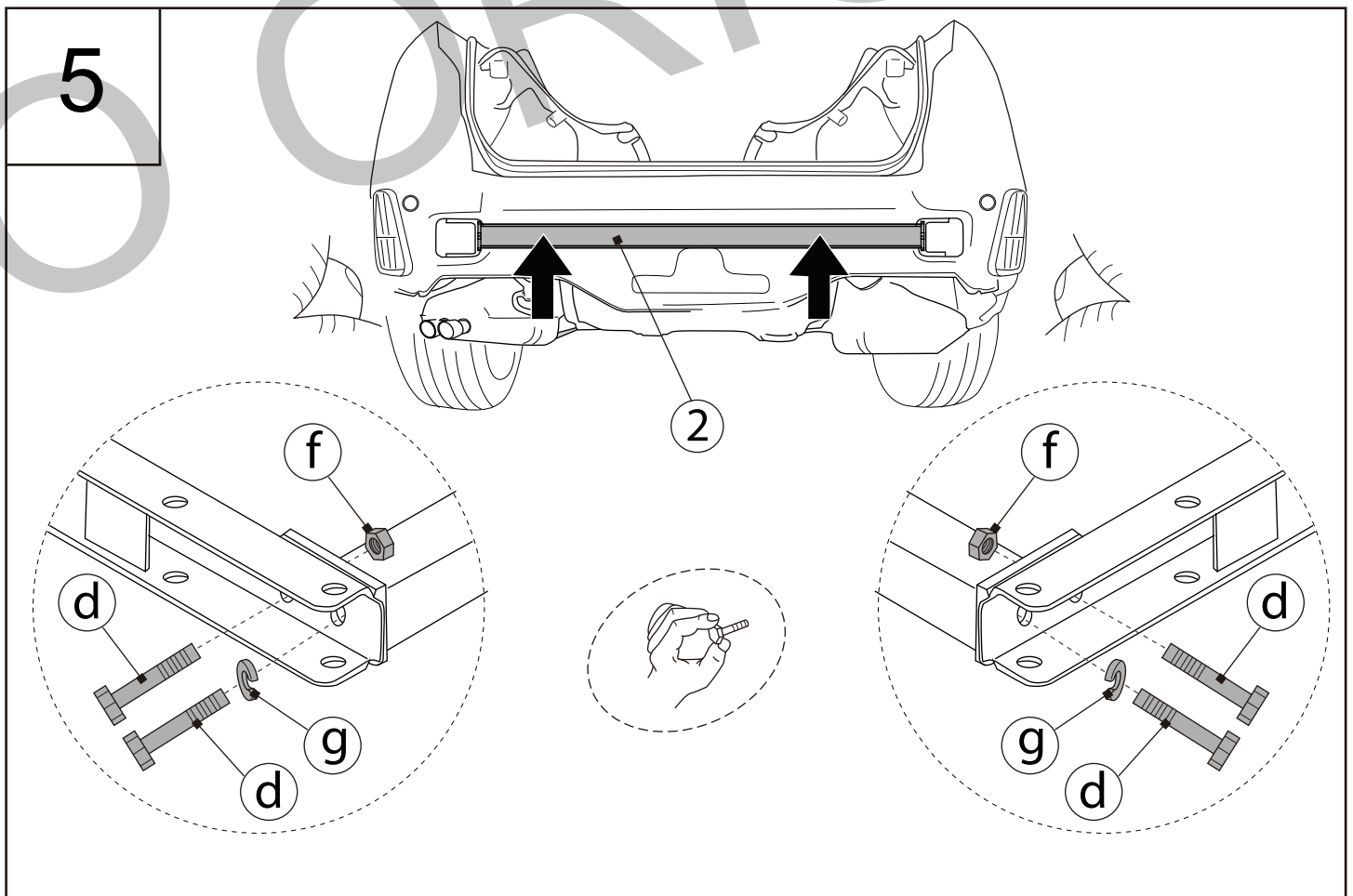
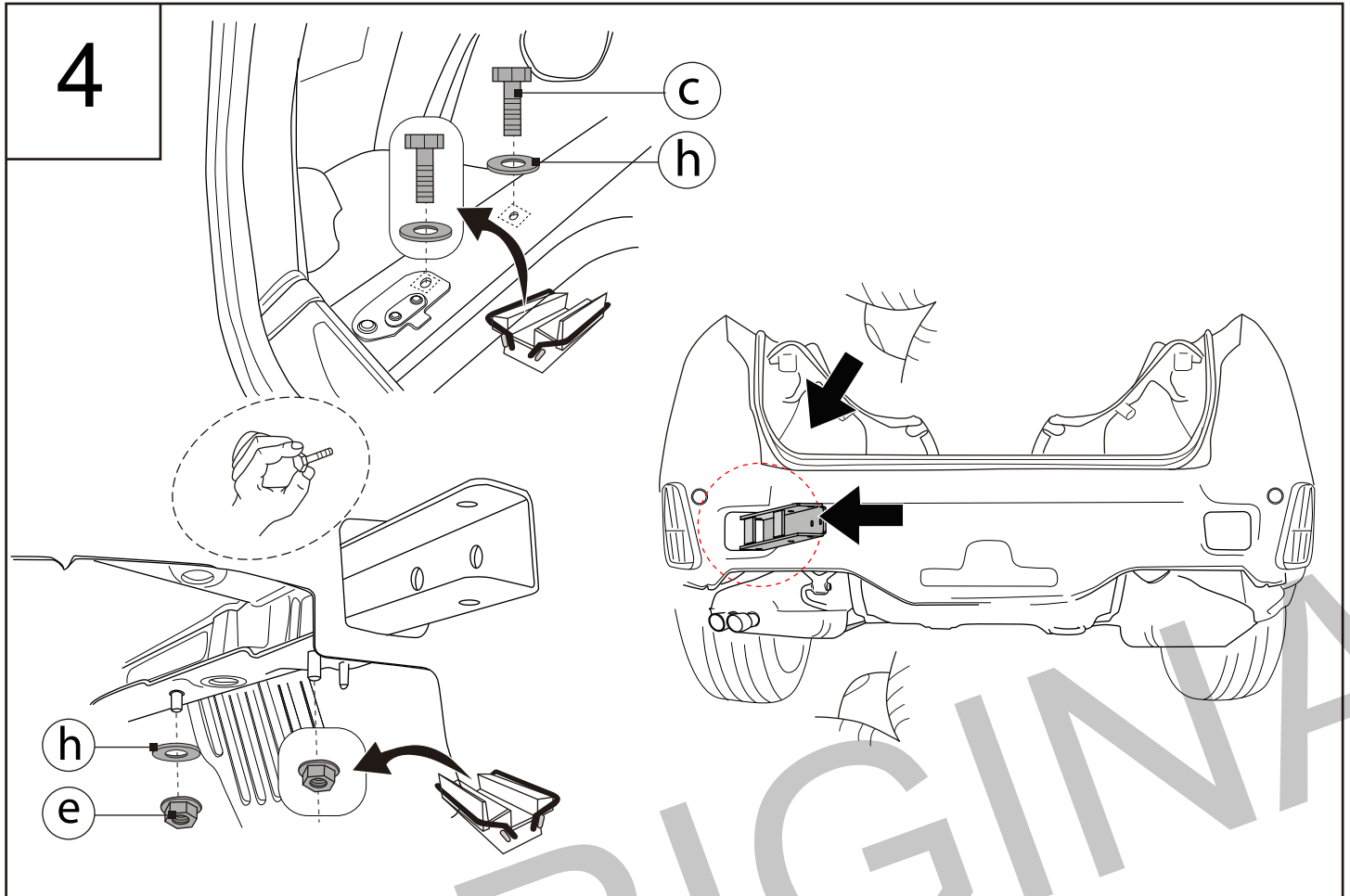

6

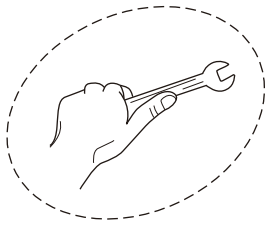

	M6	M8	M10	M12	M14	M16
8.8	10,4Nm	25,0Nm	51,0Nm	87,0Nm	140,0Nm	215,0Nm
10.9	15,5Nm	37,0Nm	75,0Nm	130,0Nm	205,0Nm	310,0Nm
12.9	18,0Nm	43,0Nm	87,0Nm	150,0Nm	240,0Nm	370,0Nm

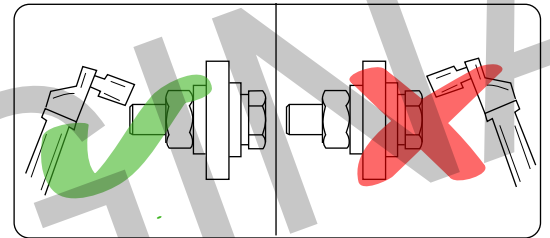
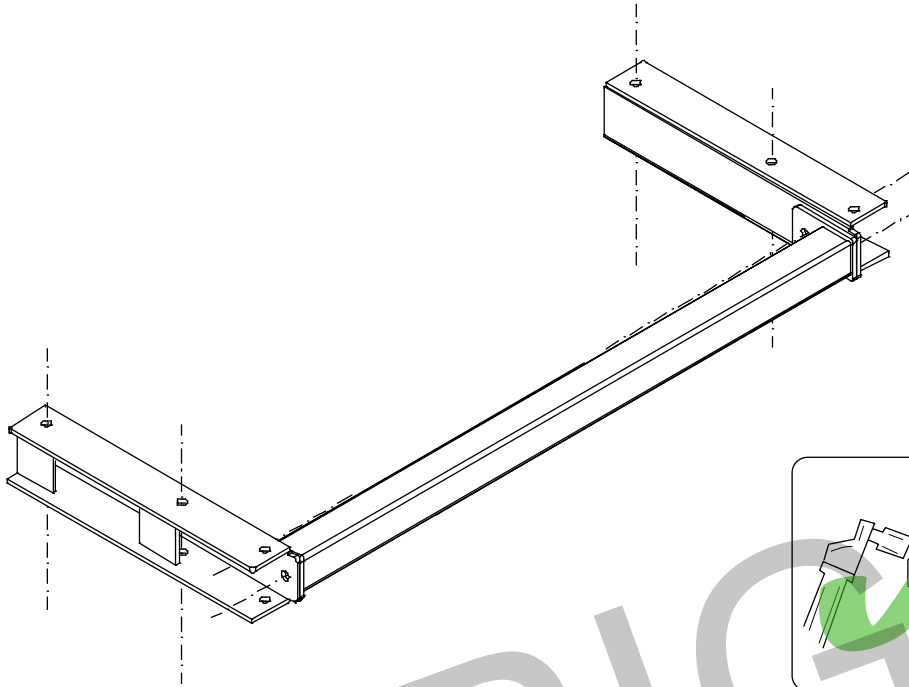

7

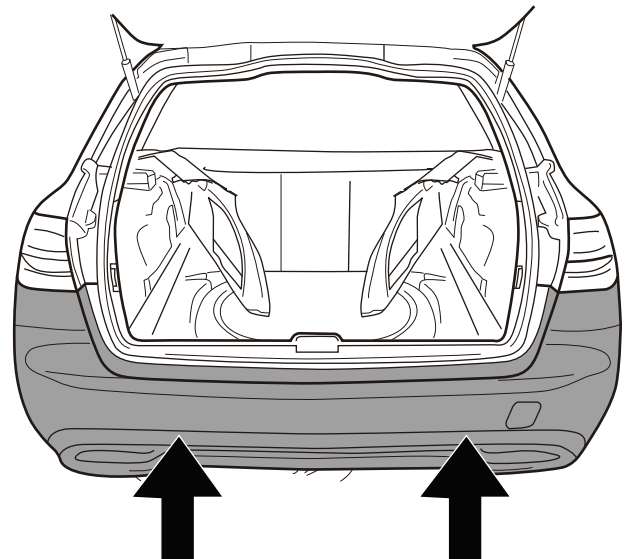
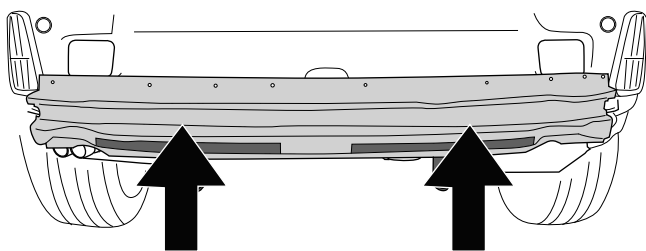
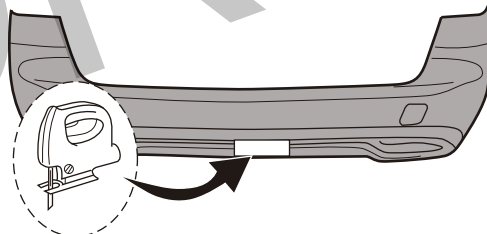

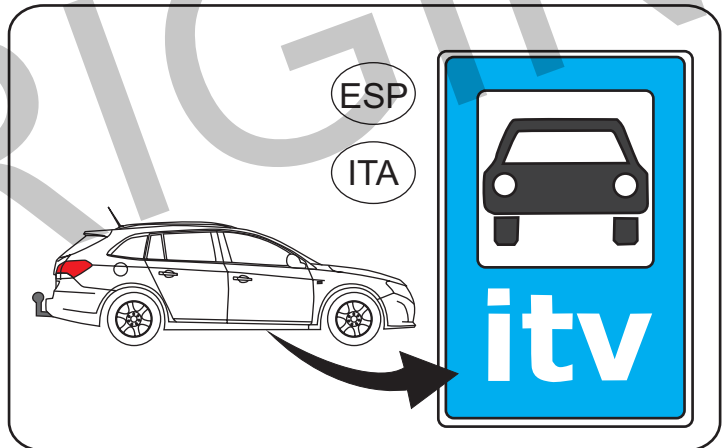
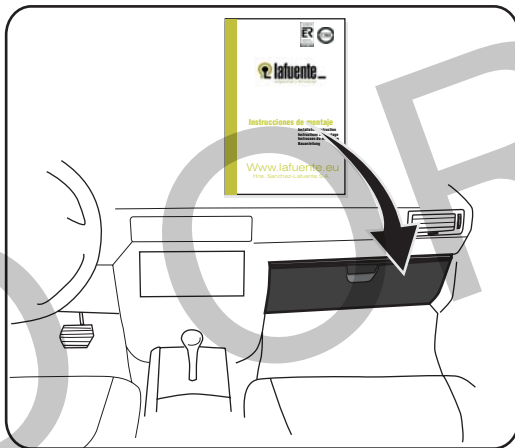
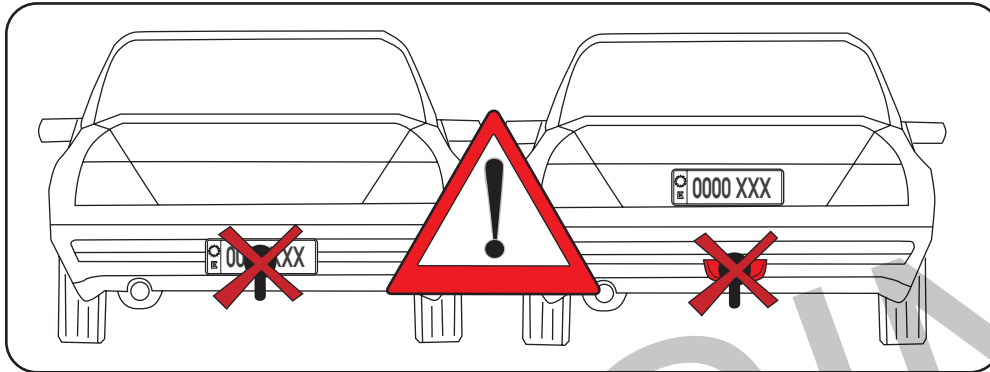
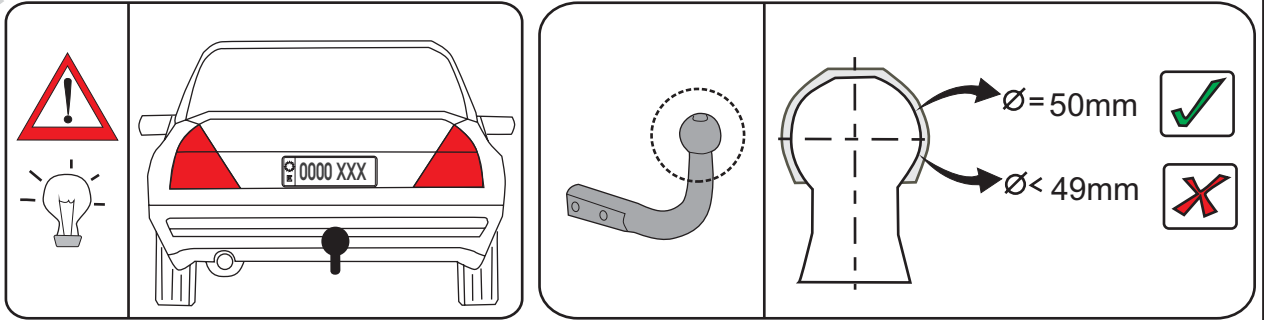
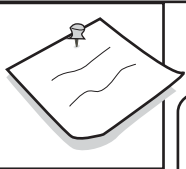

	M6	M8	M10	M12	M14	M16
8.8	10,4Nm	25,0Nm	51,0Nm	87,0Nm	140,0Nm	215,0Nm
10.9	15,5Nm	37,0Nm	75,0Nm	130,0Nm	205,0Nm	310,0Nm
12.9	18,0Nm	43,0Nm	87,0Nm	150,0Nm	240,0Nm	370,0Nm

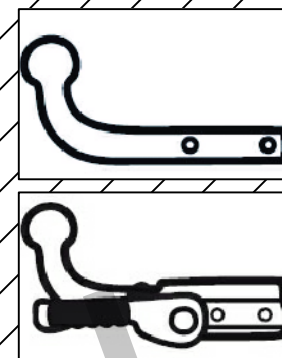
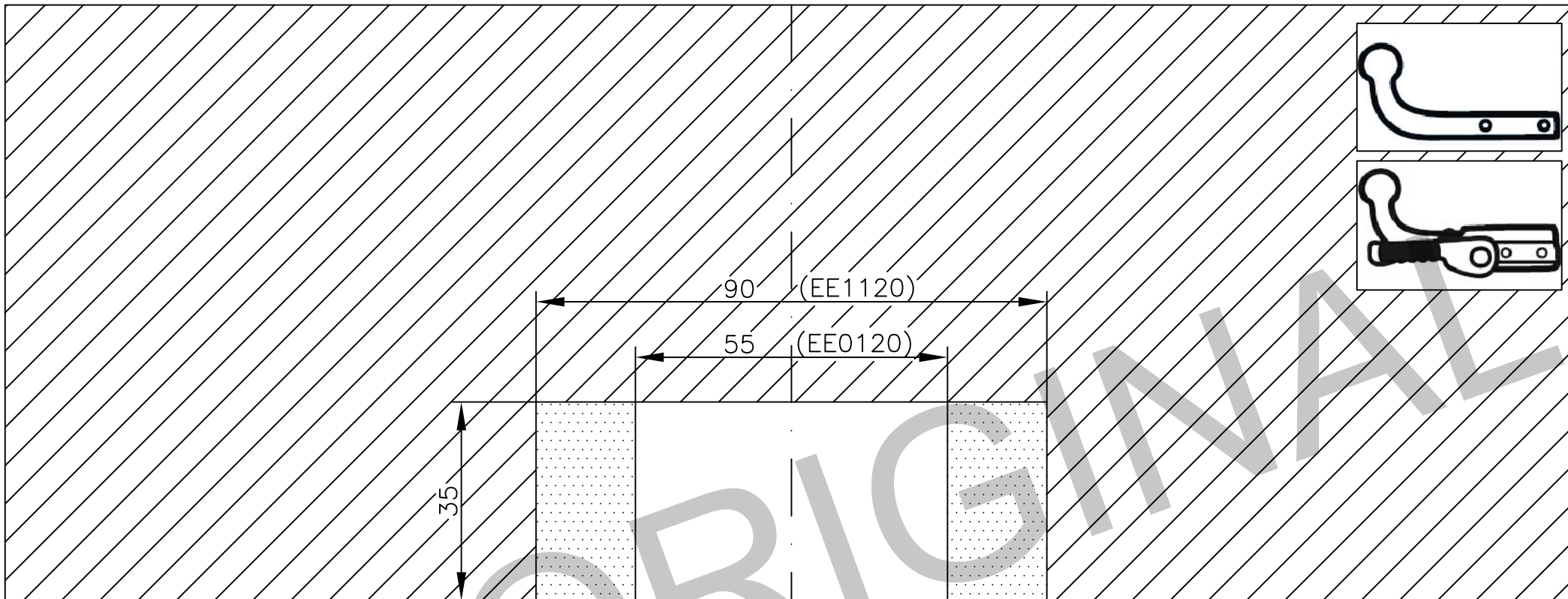

NO ORIGINAL

LINEA CENTRAL DEL PARAGOLPES

		Dibujo: CORTE PARAGOLPES AUDI A4 SEDAN / AVANT	
Escala: 1:1	UNIDADES EN mm	EE0120-EE1120	Rev. P1