





VW	TOUAREG	Nº de homologación Official approval number Prüfung Nr. Nº d'homologation
PORSCHE	CAYENNE	
AUDI	Q 7	
	EE0185	e9*94/20*94/20*2913*01
	EE1185	e9*94/20*94/20*8064*01

M.M.R. 	S 	D 	Par de apriete para los tornillos Tightening torque for bolts Schrauben Drehmoment Couple de serrage pour vis						
3500 kg	140 kg	16,13 kN	mm	6	8	10	12	14	16
			Nm	10	25	55	85	135	200

Enganche homologado según Directiva 94/20 CE.
Hitch officially approved in accordance with Directive 94/20 CE.
Geprüfte Kupplung gemäß Kennzeichen 94/20 CE.
Crochet homologué selon la Directive 94/20 CE.

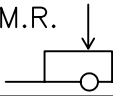
EE0185
e9*94/20*94/20*2913*01

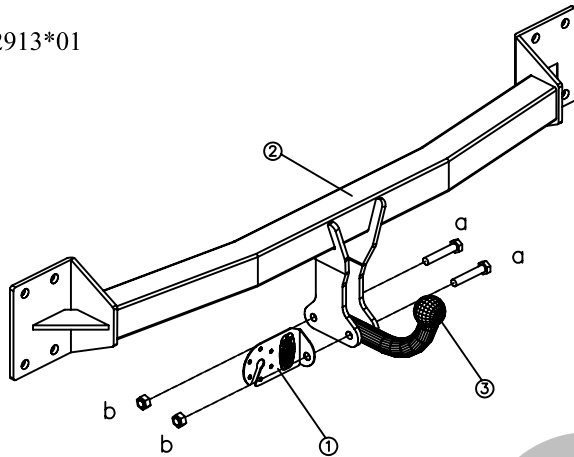



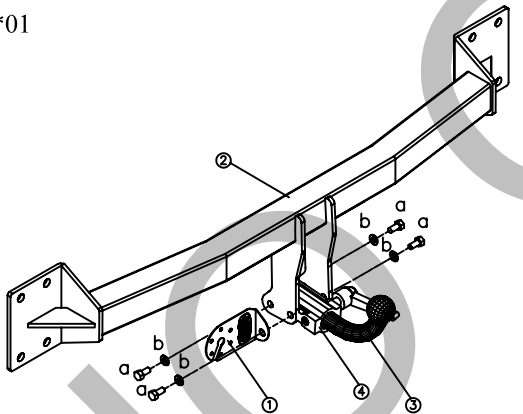



EE1185
e9*94/20*94/20*8064*01



ELEMENTOS DE UNIÓN / CONNECTION COMPONENTS
DAZUGEHÖRENDEN TEILEN / ÉLÉMENTS DE RACCORD

BOLA / BALL / KUGEL / BOULE

				
a		2 x	M12x65	8.8
b		2 x	M12	8
				
a		4 x	M12x25	8.8
b		4 x	M12 PLANA	-

E INSTRUCCIONES DE MONTAJE

1. Desmontar los pilotos traseros.
2. Desmontar el paragolpes, desechar el refuerzo interior del paragolpes.
3. Montar el enganche con los mismos tornillos del refuerzo del paragolpes.
4. Hacer muesca en el paragolpes según la figura adjunta.

UK INSTALLATION INSTRUCTIONS

1. Remove the rear lights.
2. Remove the bumper, discard the inner bumper reinforcement.
3. Fit the tow bar with the same screws as the bumper reinforcement.
4. make a notch in the bumper as shown in the diagram.

D BAUANLEITUNG

1. Herausnehmen der Beleuchtung hinten.
2. Herausnehmen der Stossfänger hinten, die Halterungen weglassen.
3. Fixieren die Kupplung mit den Gleichen Schrauben der Halterung des Stossfängers.
4. Ausschneiden der Stossfänge, (siehe Anlage).
5. Schrauben entsprechend der Drehmomenttabelle festziehen.

F IMNSTRUCTIONS DE MONTAGE

1. Démonter les voyants arrière.
2. Démonter le pare-chocs, jeter le renfort intérieur du pare-chocs.
3. Monter l'attelle avec les vis du renfort du pare-chocs.
4. Faire une encoche dans le pare-chocs selon la figure ci-jointe.

P INSTRUÇÕES DO MONTAGEM

1. Desmontar os pilotos traseiros.
2. Desmontar o pára-choques, desapertar o reforço interior do pára-choques.
3. Montar o engate com os mesmos parafusos do reforço do pára-choques.
4. Fazer um entalhe no pára-choques segundo a figura junta.

I ISTRUZIONI DI MONTAGGIO

1. Smontare le luci posteriori.
2. Smontare il paraurti, disfarsi del rinforzo interno del paraurti.
3. Montare il gancio con le stesse viti del rinforzo del paraurti.
4. Realizzare una tacca nel paraurti come mostra la figura annessa.

Montaje de bola/ Ball installation/ Montage der Kugel/ Montage de la boule/ Montagem de bola

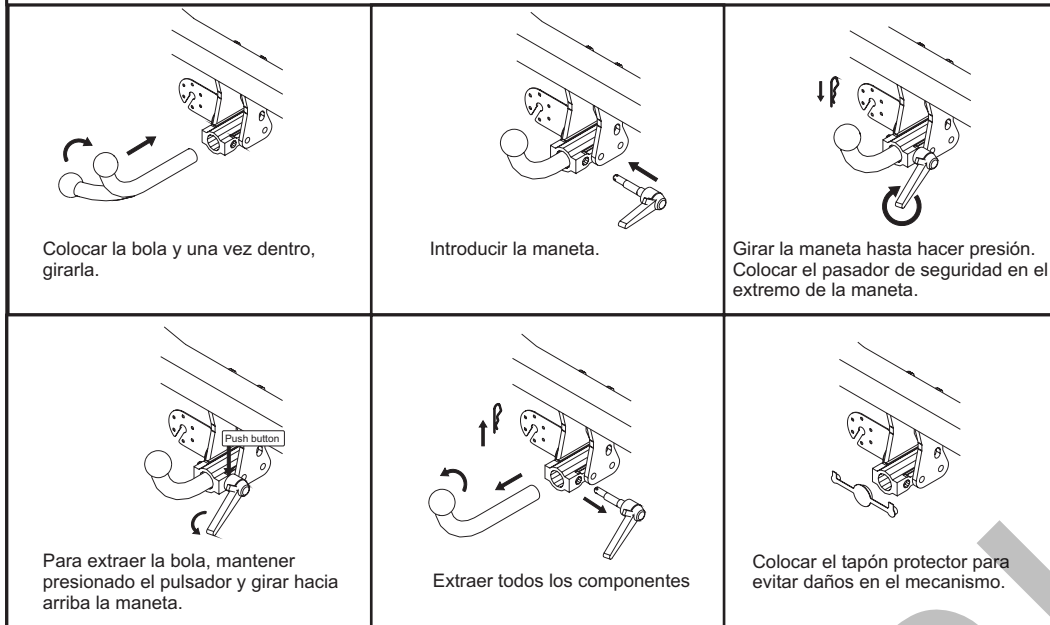

SEPARACION MINIMA DE LA BOLA

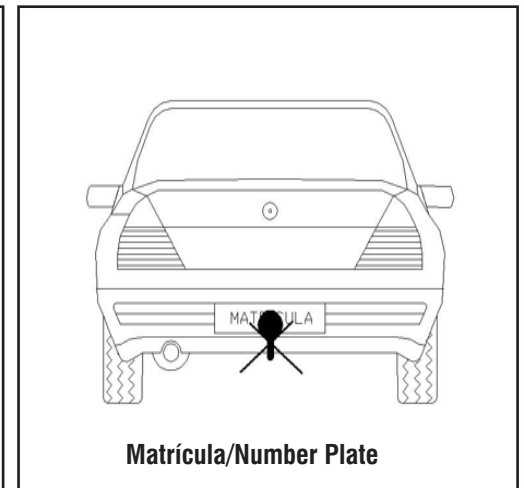
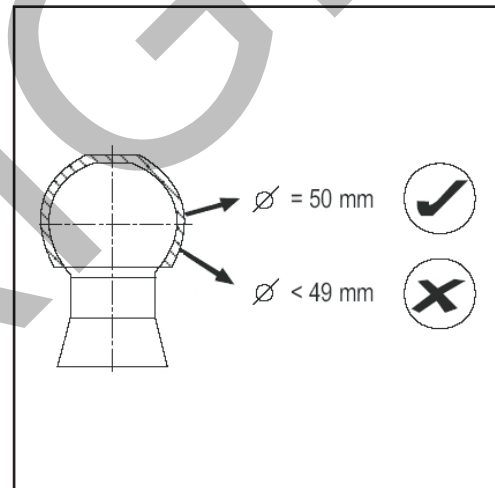
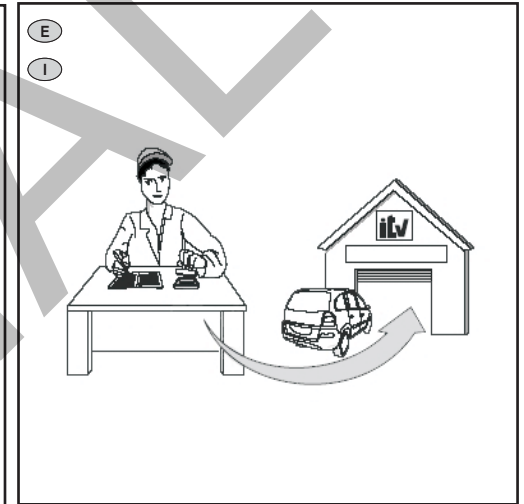
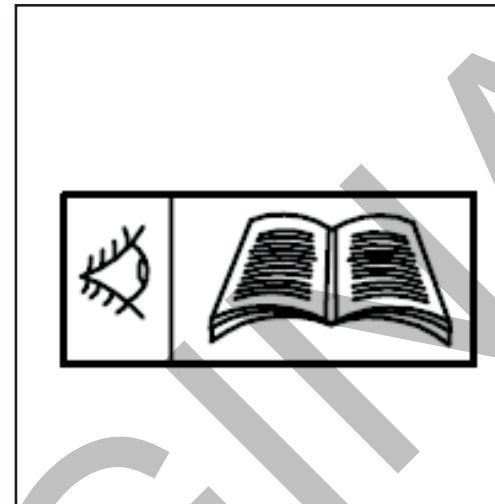
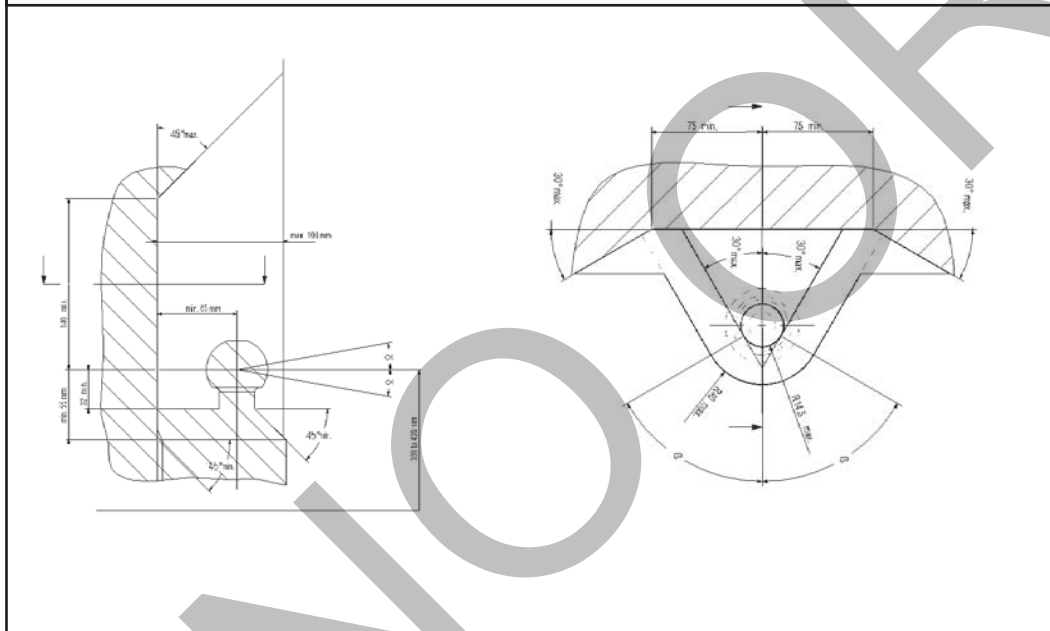

- Nota / Note / Bemerkung / Remarque:

- E** Revisar par de apriete de tornillos a los 6 meses/1.000 Km. de uso.
- UK** Check the bolt torque after 6 months or 1000 km of use.
- D** Schrauben nach 6 Monaten/1.000 Km. Lausleistung überprüfen.
- F** Vérifier le serrage des vis tous les 6 mois /1000 Km d'utilisation.
- P** Revisar Par de Apertado de parafusos todos os 6 meses/1.000 Km. de uso.
- I** Si raccomanda di revisionare il perfetto serraggio dopo aver percorso i primi 1000 Km. Di

PLANTILLA PARA CORTE DE PARAGOLPES

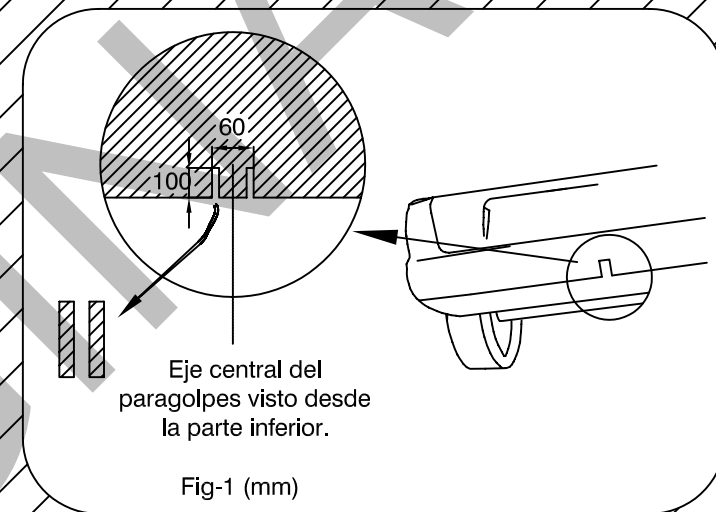
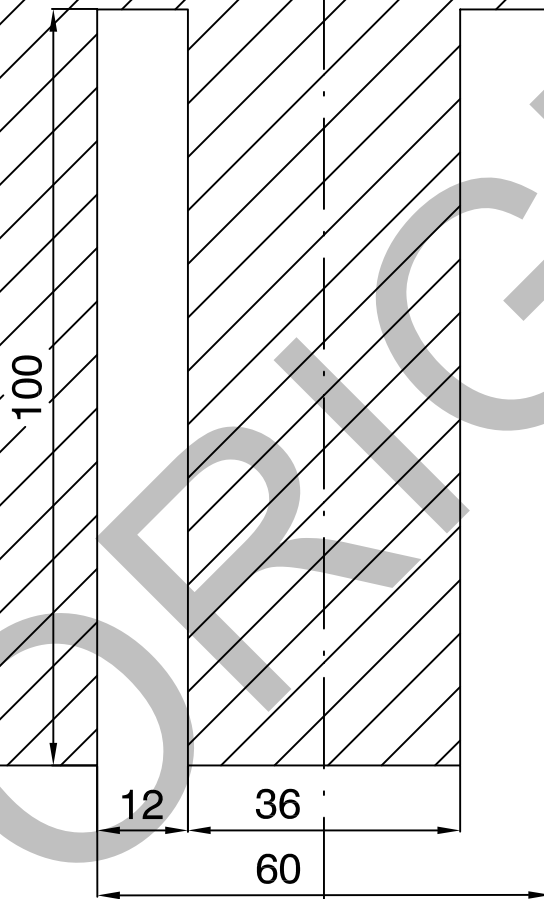

Eje central del
paragolpes visto desde
la parte inferior.

Fig-1 (mm)

LINEA CENTRAL DEL PARAGOLPES



**Hnos. SÁNCHEZ
LAFUENTE, S.A**

Dibujo:

DETALLE DE VENTANA A REALIZAR EN EL
PARAGOLPES

Escala:
1:1

UNIDADES EN
mm

EE0185- VW.TOUAREG
BOLA FIJA

Rev.
P1

PLANTILLA PARA CORTE DE PARAGOLPES

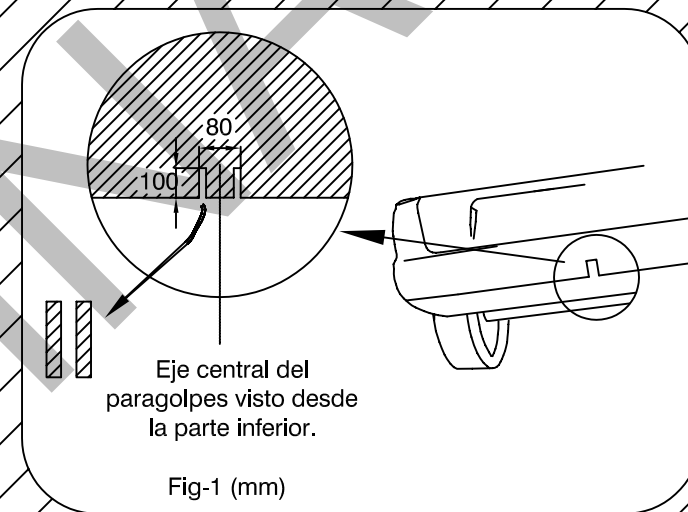
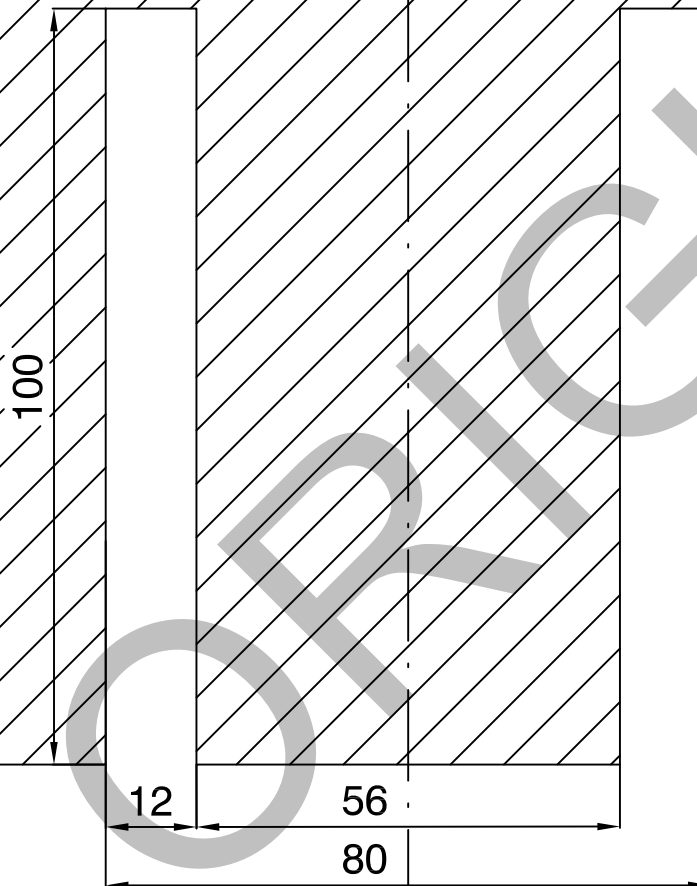

LINEA CENTRAL DEL PARAGOLPES



**Hnos. SÁNCHEZ
LAFUENTE, S.A**

Dibujo:

DETALLE DE VENTANA A REALIZAR EN EL
PARAGOLPES

Escala:
1:1

UNIDADES EN
mm

EE1185- VW. TOUAREG
BOLA DESMONTABLE

Rev.
P1

PLANTILLA PARA CORTE
DE PARAGOLPES

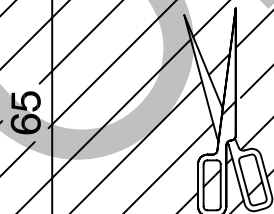
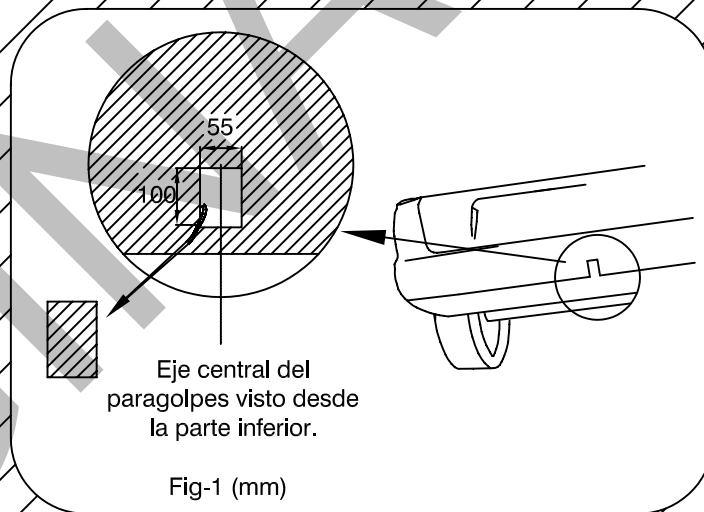
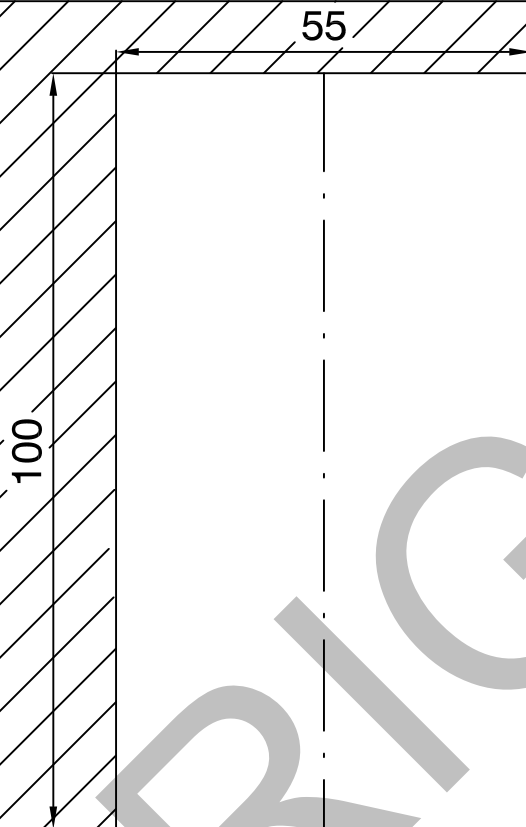

LINEA CENTRAL DEL PARAGOLPES



**Hnos. SÁNCHEZ
LAFUENTE, S.A**

Dibujo:

DETALLE DE VENTANA A REALIZAR EN EL
PARAGOLPES

Escala:
1:1

UNIDADES EN
mm

EE0185- AUDI Q7
BOLA FIJA

Rev.
P1

PLANTILLA PARA CORTE
DE PARAGOLPES

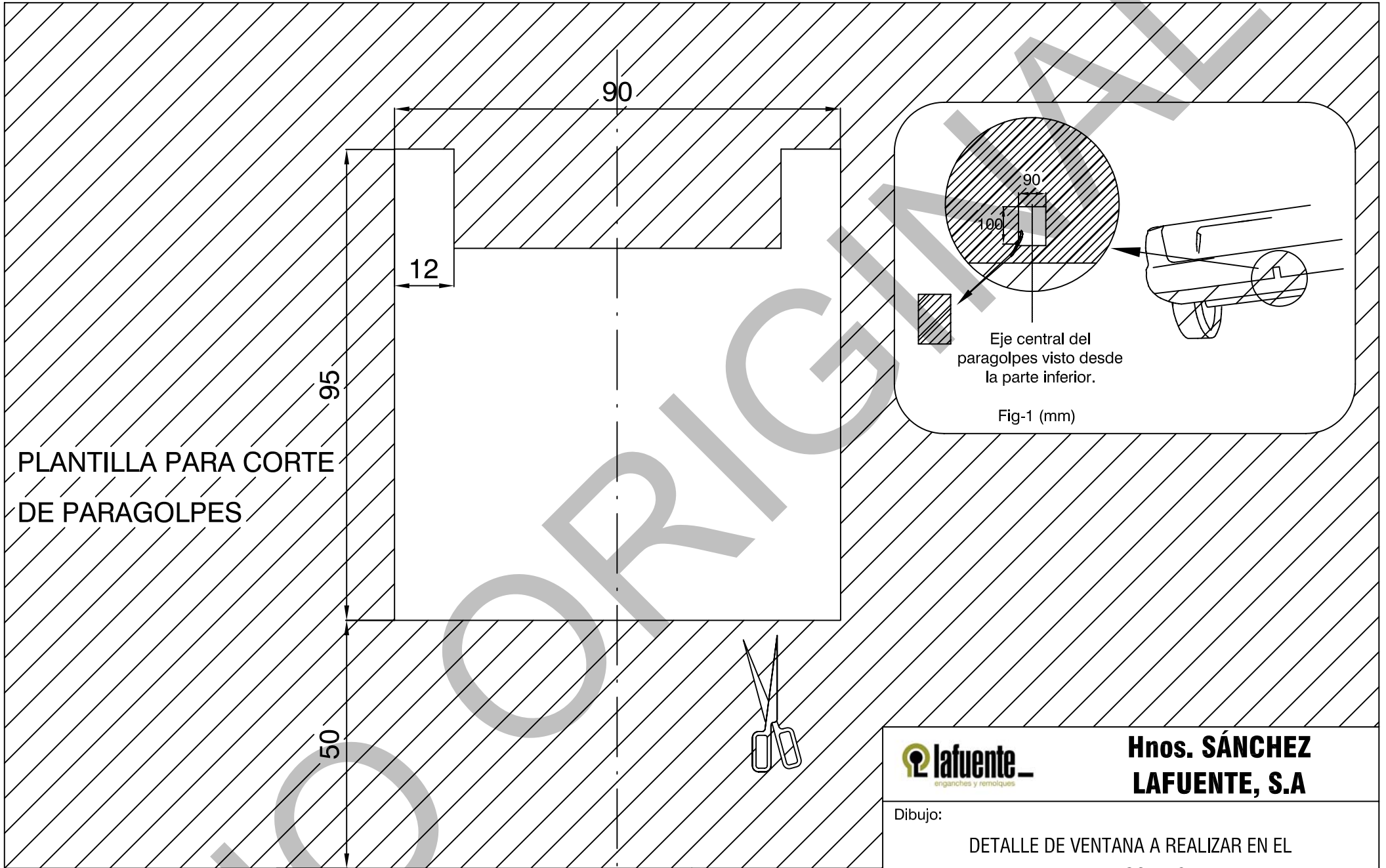

LINEA CENTRAL DEL PARAGOLPES



**Hnos. SÁNCHEZ
LAFUENTE, S.A**

Dibujo:
DETALLE DE VENTANA A REALIZAR EN EL
PARAGOLPES

Escala: 1:1	UNIDADES EN mm	EE1185- AUDI Q7 BOLA DESMONTABLE	Rev. P1
----------------	-------------------	-------------------------------------	------------