

	SEAT LEON SKODA SUPERB SKODA SUPERB COMBI SKODA OCTAVIA SEDAN SKODA OCTAVIA COMBI AUDI A3 SPORTBACK	Nº de homologación Official approval number Prüfungs Nr. Nº d'homologation
	EE02332	e9*94/20*94/20*8023*02
	EE12332	e9*94/20*94/20*8024*02



lafuente

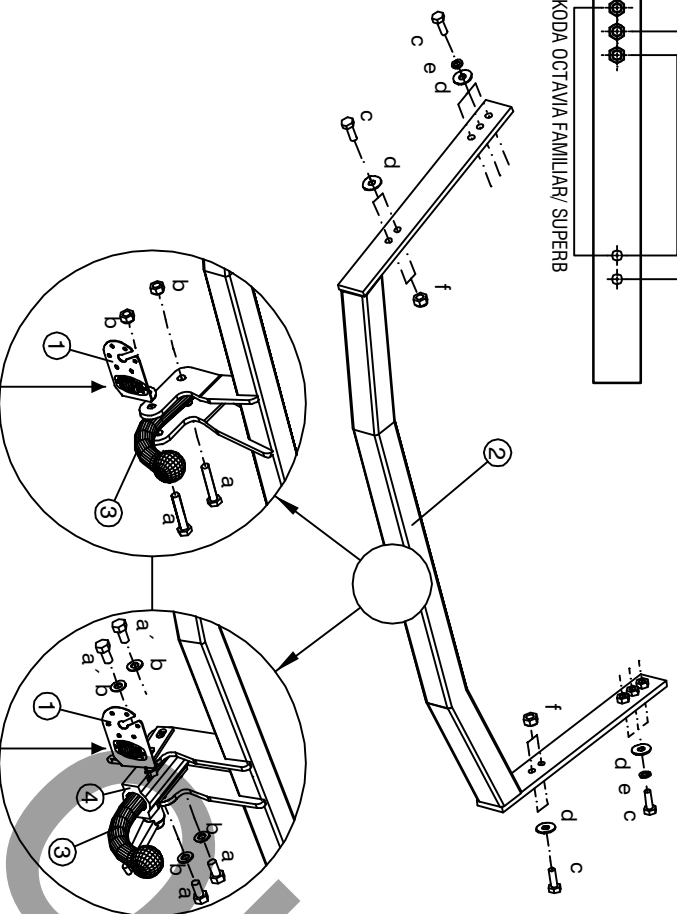
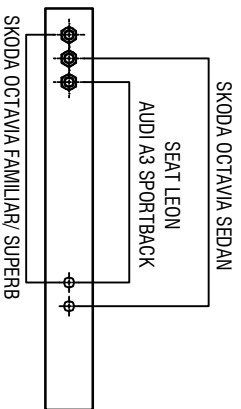

e9 | 00*8023
 TP0 | EE02332
 CLASE A-50X
 D | 9,71 kN
 S | 80 kg

Made by LAFUENTE (SPAIN)
 Tlf: (+34) 952 625 840
 www.lafuente.eu

lafuente

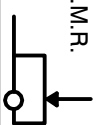

e9 | 00*8024
 TP0 | EE12332
 CLASE A-50X
 D | 9,71 kN
 S | 80 kg

Made by LAFUENTE (SPAIN)
 Tlf: (+34) 952 625 840
 www.lafuente.eu

M.M.R.				
1.950 kg.	80 kg.	9,71 kN		

Par de apriete para los tornillos	
Tightening torque for bolts	
Schrauben Drehmoment	
Couple de serrage pour vis	
mm	6 8 10 12 14 16
Nm	10 25 55 85 135 200

Enganche homologado según Directiva 94/20 CE.
 Hitch officially approved in accordance with Directive 94/20 CE.
 Geprüfte Kupplung gemäß Kennzeichen 94/20 CE.
 Crochet homologué selon la Directive 94/20 CE.

ELEMENTOS DE UNIÓN / CONNECTION COMPONENTS DAZUGEHÖRENDE TEILEN / ÉLÉMENTS DE RACCORD		VEHÍCULO / VEHICLE FAHRZEUG / VÉHICULE		
				
a	2 x M12x65 DIN 931	8.8	c 4 x M10x40 DIN 933	8.8
b	2 x M12 DIN 985	8	d 4 x M10 DIN 9021	-
			e 2 x M 10 DIN 127	-
a	2 x M12x25DIN 933	8.8	f 2 x M10 DIN 985	8
a'	2 x M12x30 DIN 933	8.8		
b	4 x M12 DIN 125	-		

Este documento debe ser presentado en la I.T.V. junto con el certificado de montaje.

HNOS.SÁNCHEZ-LAFUENTE.S.A. no asume ningún tipo de responsabilidad por daños causados por usos inadecuados.

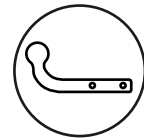

EE0232

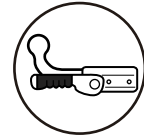

EE1232

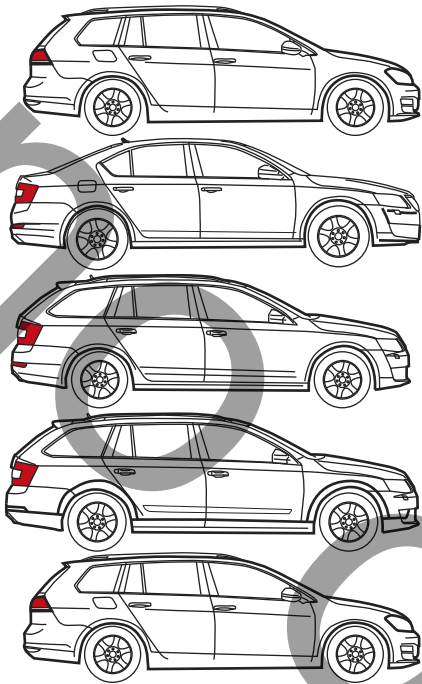

SEAT LEON
SKODA OCTAVIA SEDAN
SKODA OCTAVIA COMBI
SKODA SUPERB
SKODA SUPERB COMBI
AUDI A3 SPORTBACK

Instrucciones de montaje - Installation instructions - Notice de montage - Montage- og driftsvejledning

1

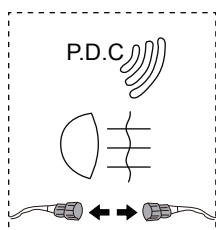
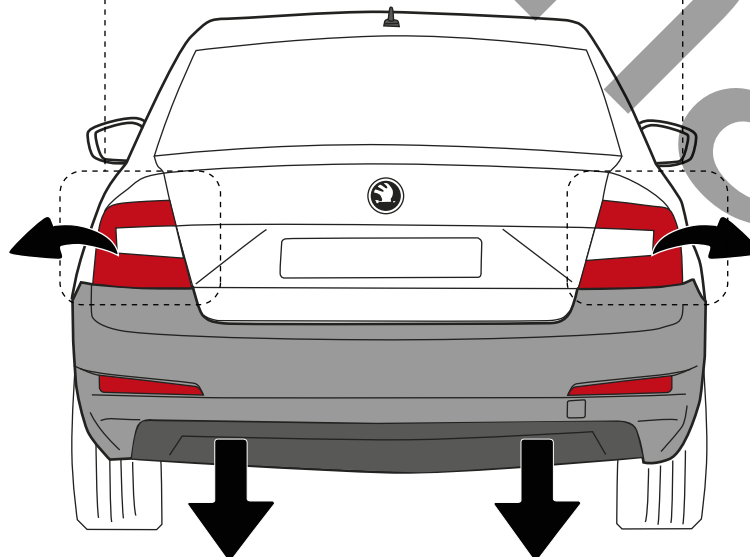
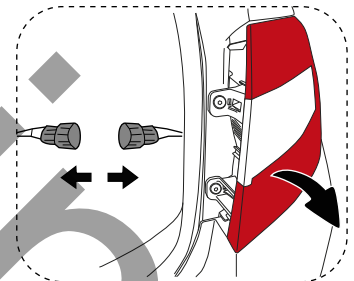
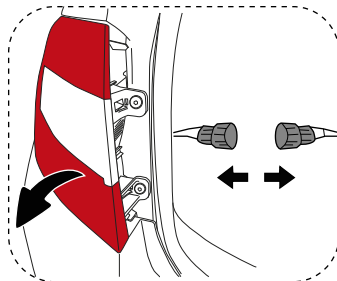

2



SKODA

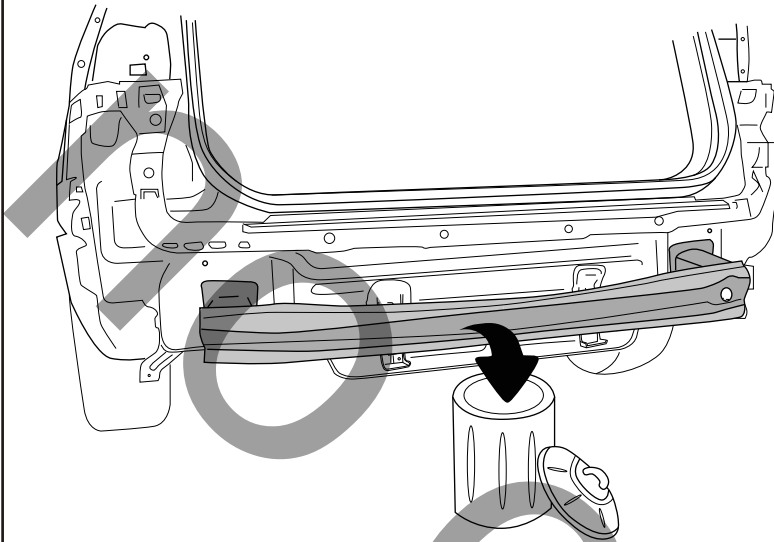
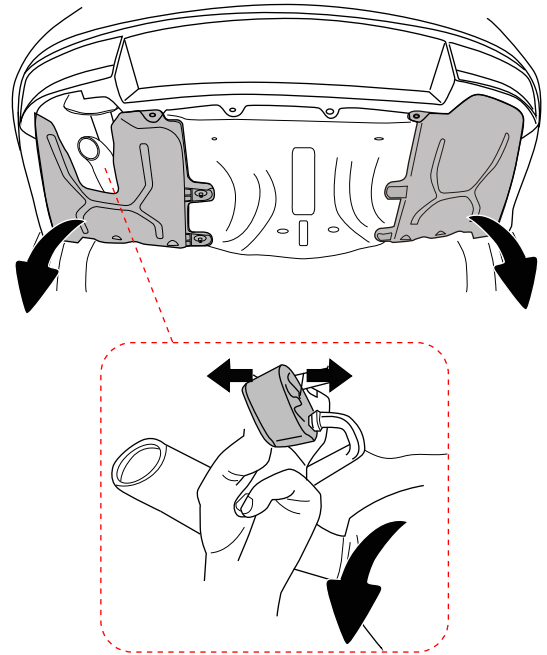

3

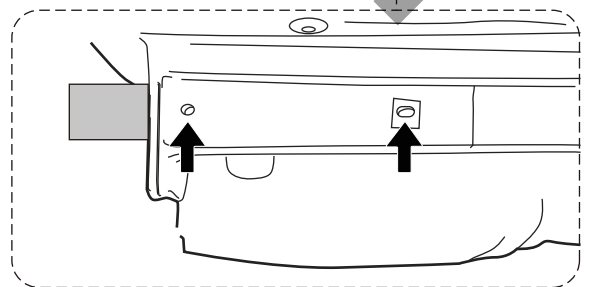
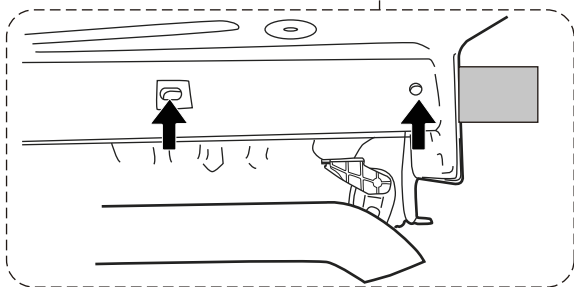
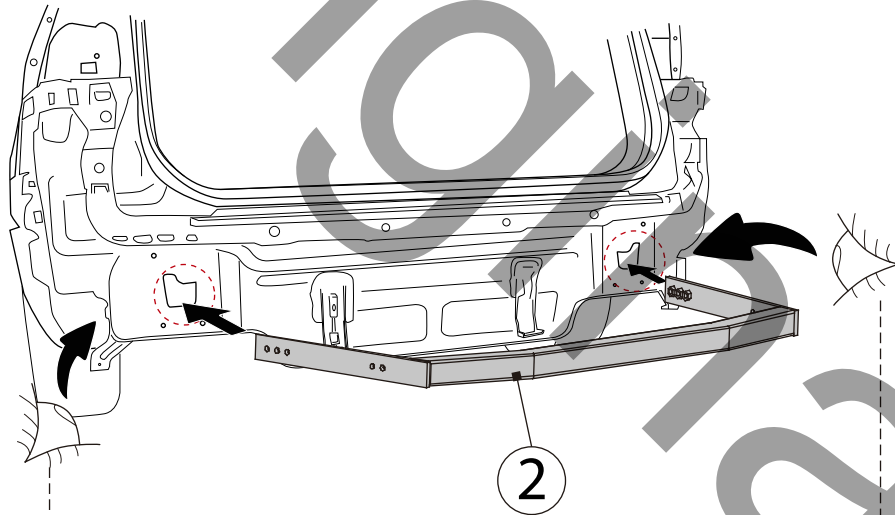

4

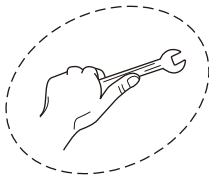

	M6	M8	M10	M12	M14	M16
8.8	10,4Nm	25,0Nm	51,0Nm	87,0Nm	140,0Nm	215,0Nm
10.9	15,5Nm	37,0Nm	75,0Nm	130,0Nm	205,0Nm	310,0Nm
12.9	18,0Nm	43,0Nm	87,0Nm	150,0Nm	240,0Nm	370,0Nm

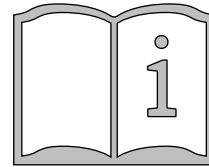
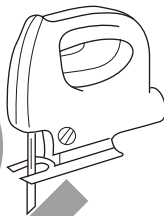
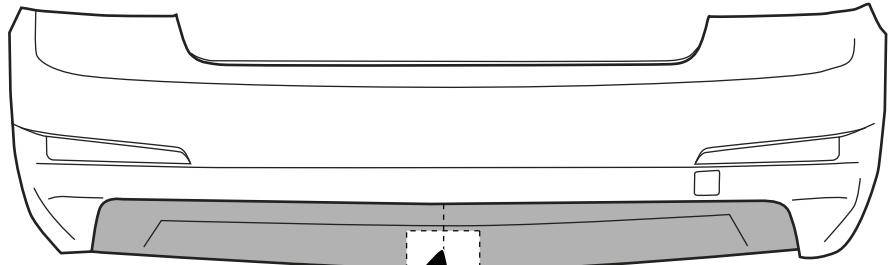

5

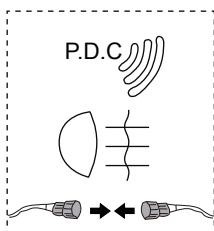
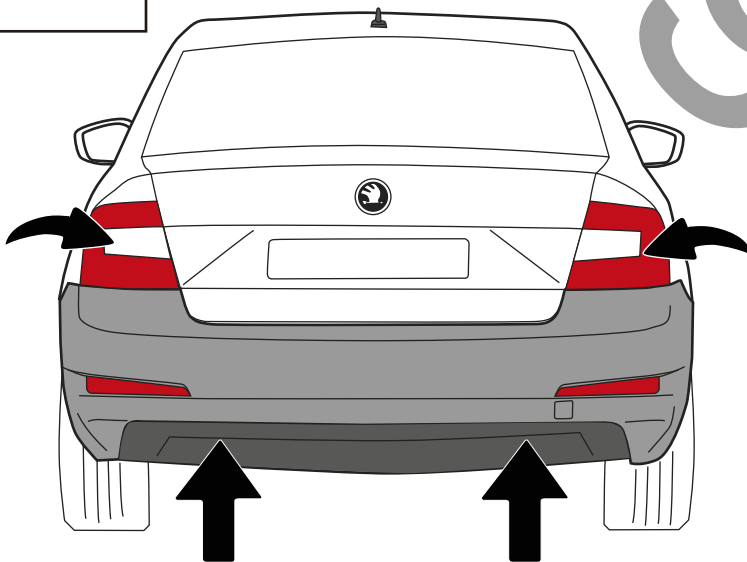

SKODA

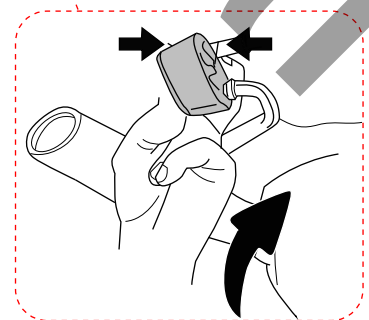
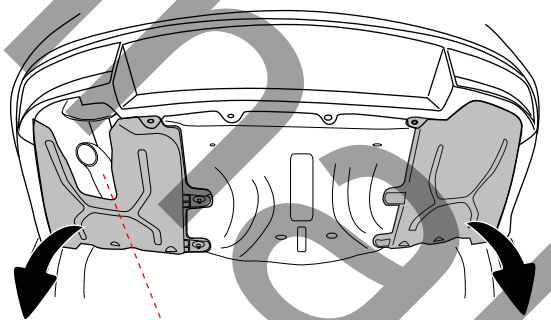

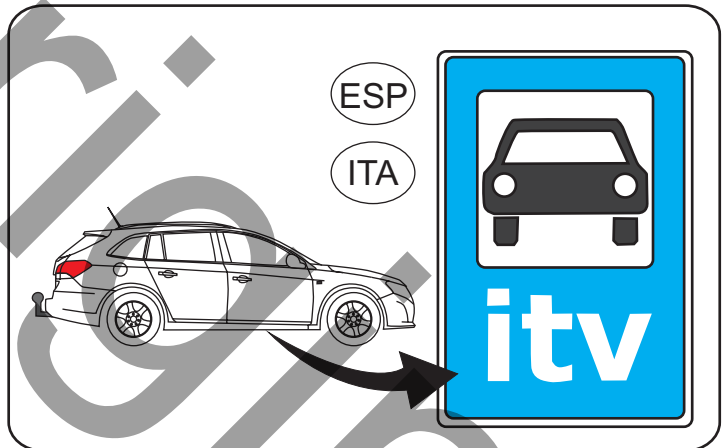
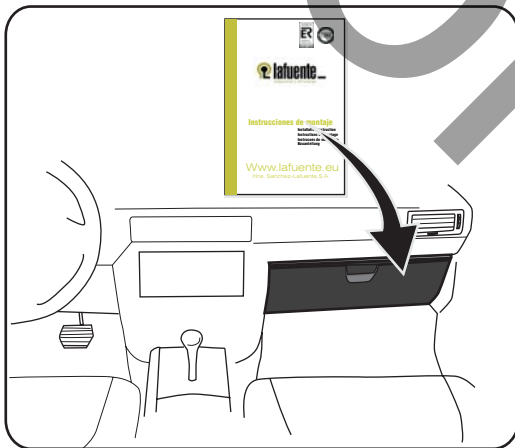
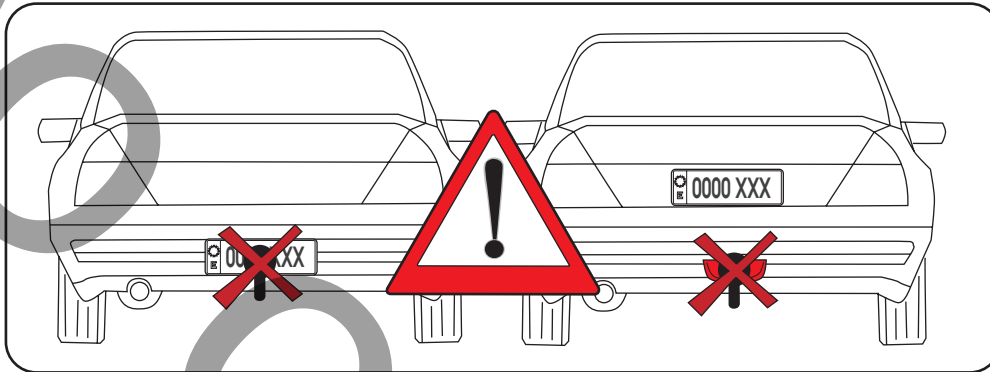
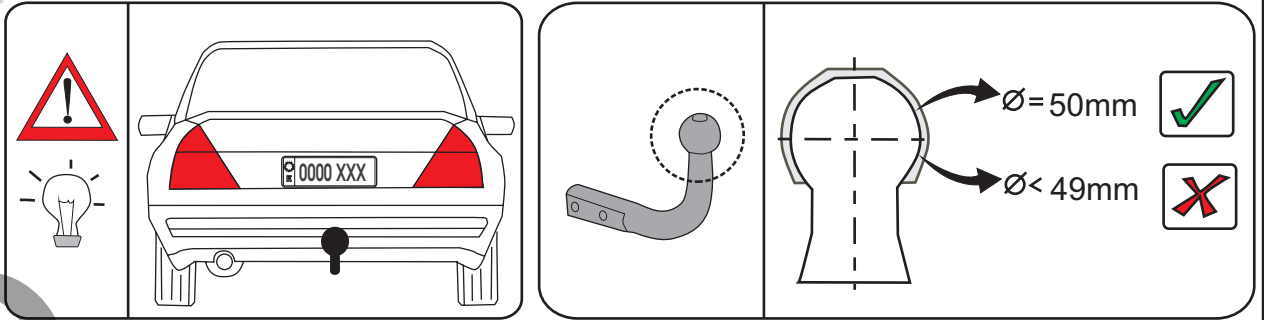
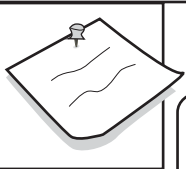

0 km
1000 km

	M6	M8	M10	M12	M14	M16
8.8	10,4Nm	25,0Nm	51,0Nm	87,0Nm	140,0Nm	215,0Nm
10.9	15,5Nm	37,0Nm	75,0Nm	130,0Nm	205,0Nm	310,0Nm
12.9	18,0Nm	43,0Nm	87,0Nm	150,0Nm	240,0Nm	370,0Nm

SKODA OCTAVIA BERLINA (2004-2013)

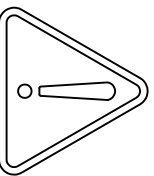
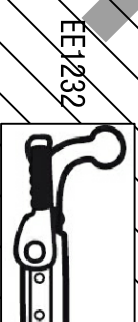
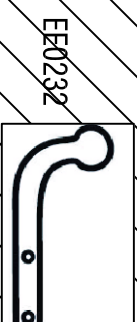
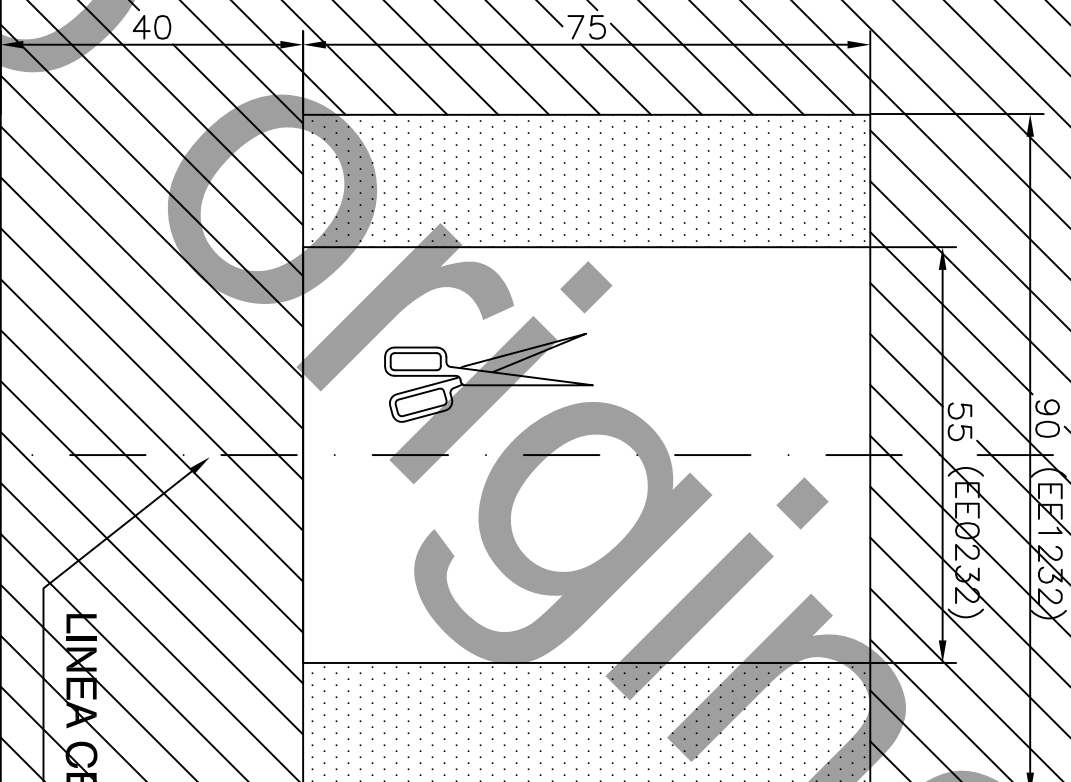

ESP: El corte es orientativo
UK: The cut is indicative



Escala: 1:1
UNIDADES EN mm

Dibujo:

CORTE PARAGOLPES
SKODA OCTAVIA BERLINA

EE0232-EE1232

Rev. P1

SKODA OCTAVIA BERLINA (2013-...)

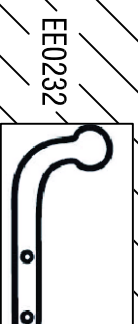
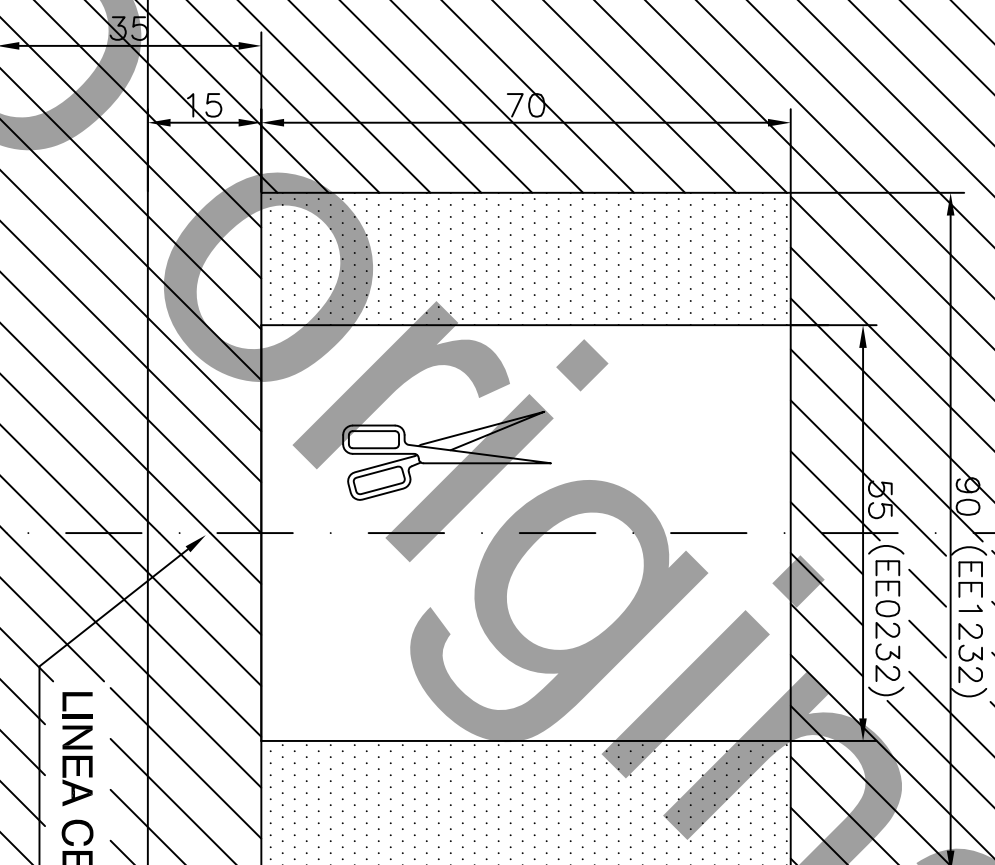

LINEA CENTRAL DEL PARAGLPPES

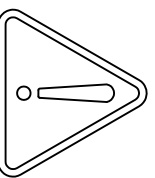

ESP: El corte es orientativo
UK: The cut is indicative



Escala: 1:1
UNIDADES EN mm

Dibujo:

CORTE PARAGOLPES
SKODA OCTAVIA BERLINA

EE0232-EE1232

Rev. P1

SKODA OCTAVIA COMBI (2004-2013)

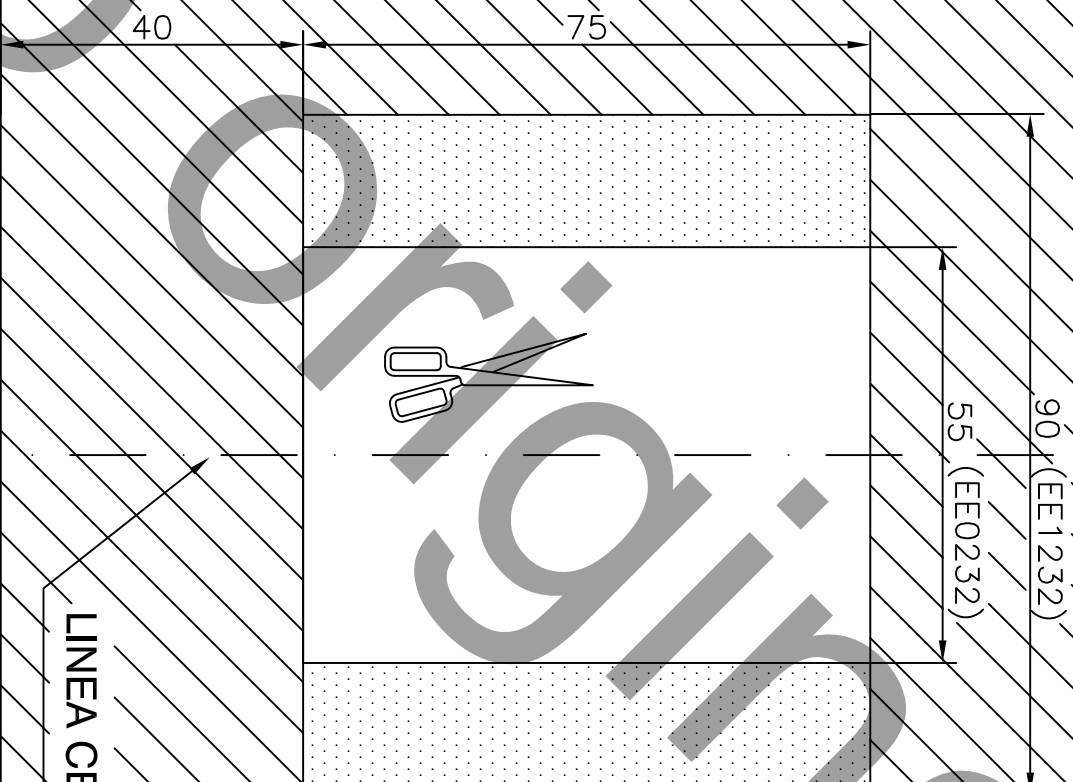

EE0232

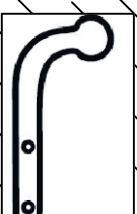

EE1232

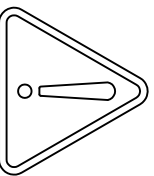

ESP: El corte es orientativo
UK: The cut is indicative



Dibujo:

CORTE PARAGOLPES
SKODA OCTAVIA COMBI

Escala: 1:1
UNIDADES EN mm

EE0232-EE1232

Rev. P1

SKODA OCTAVIA COMBI (2013-...)

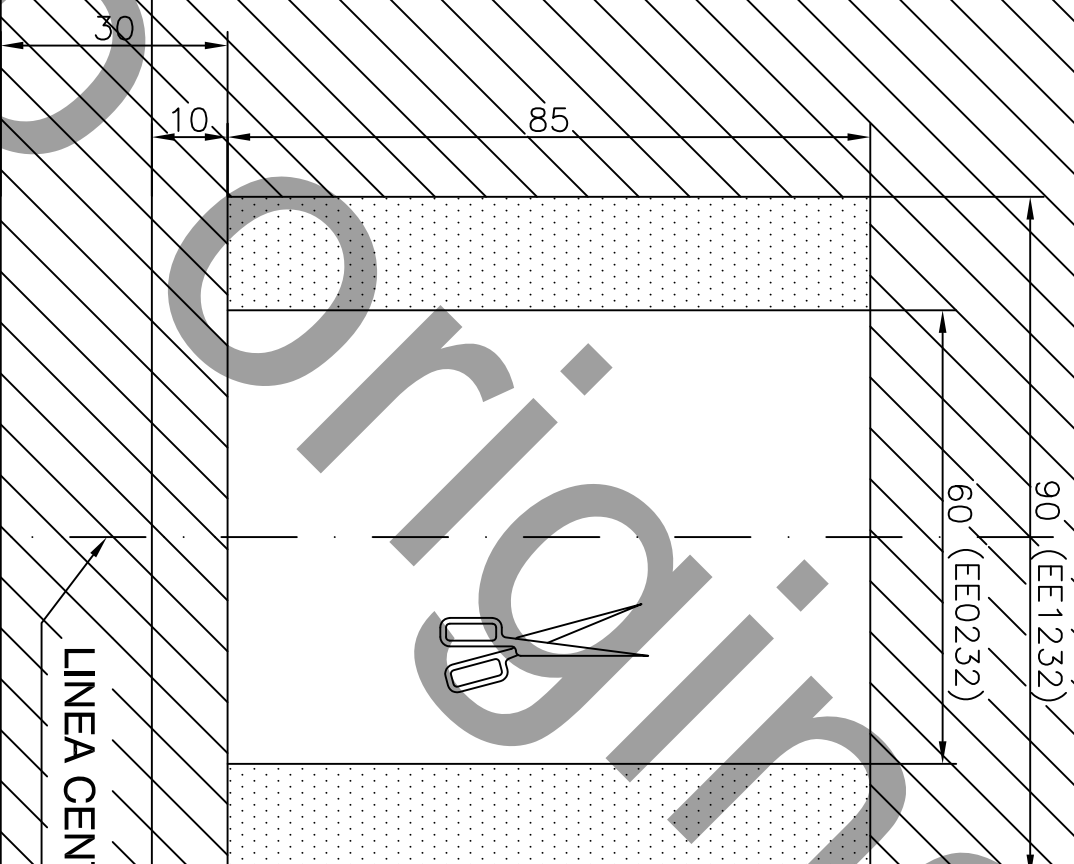

LINEA CENTRAL DEL PARAGLAPES

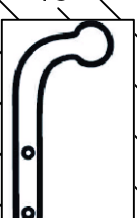

EE0232



EE1232

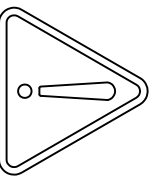

ESP: El corte es orientativo
UK: The cut is indicative



Dibujo:

CORTE PARAGLAPES
SKODA OCTAVIA COMBI

Escala:
1:1

UNIDADES EN
mm

EE0232-EE1232

Rev.
P1

SKODA OCTAVIA COMBI VRS

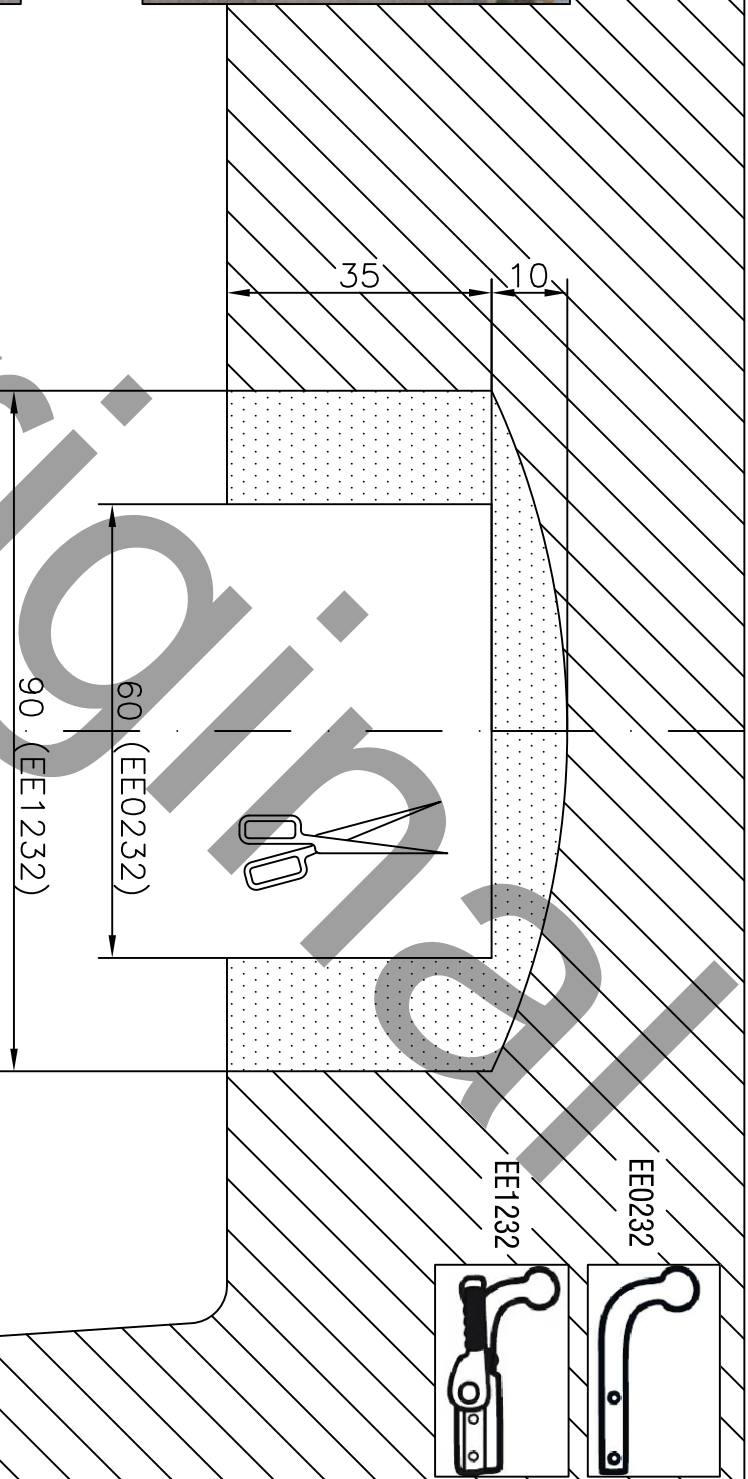

LINEA CENTRAL
DEL PARAGLPPES

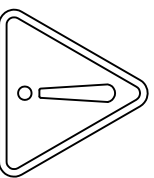

ESP: El corte es orientativo
UK: The cut is indicative



Dibujo:

CORTE PARAGOLPES

SKODA OCTAVIA COMBI VRS

Escala:
1:1 UNIDADES EN
mm

EE0232-EE1232

Rev.
P1

SKODA SUPERB BERLINA



EE0232

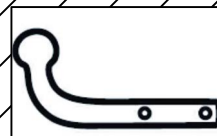

EE1232

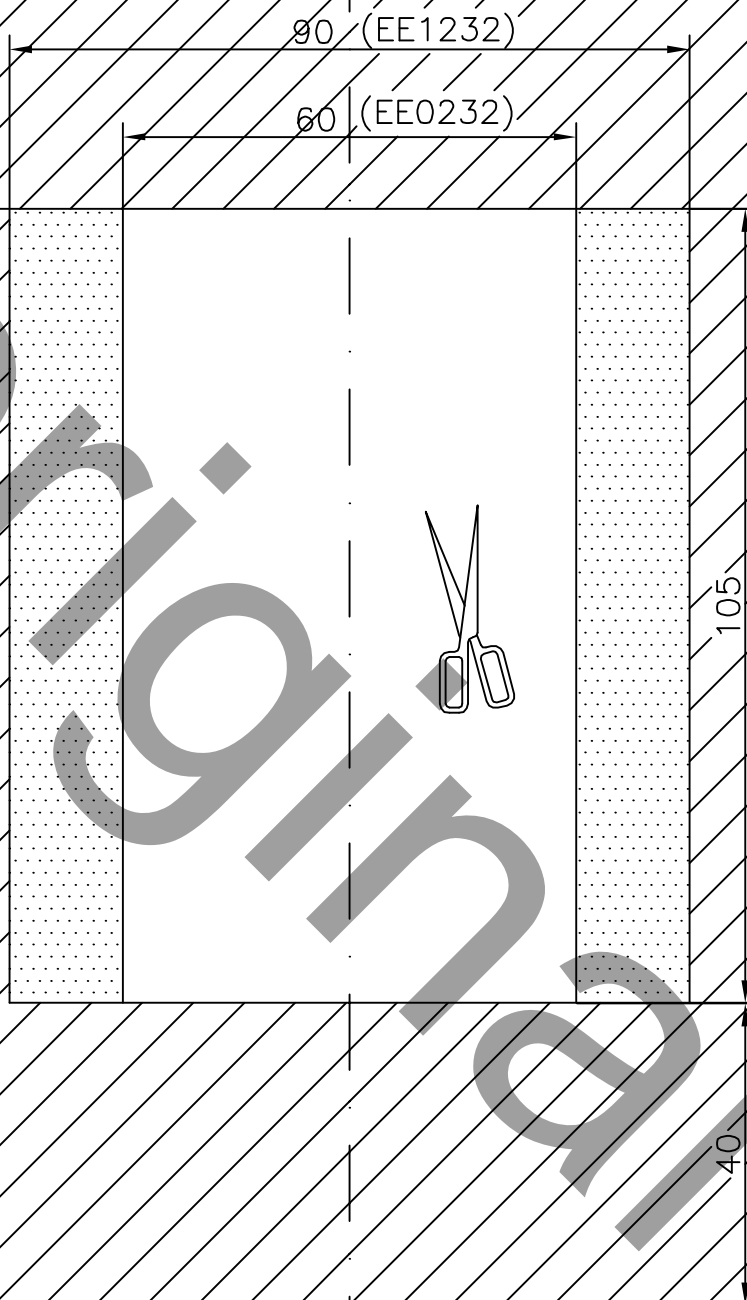

ESP: El corte es orientativo
UK: The cut is indicative



Dibujo:

CORTE PARAGOLPES
SKODA SUPERB BERLINA

Escala:
1:1

UNIDADES EN
mm

EE0232-EE1232

Rev.
P1

SKODA SUPERB COMBI



EE0232

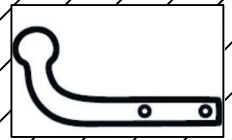

EE1232

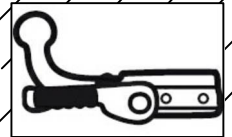

100 (EE1232)

70 (EE0232)

115

25



ESP: El corte es orientativo
UK: The cut is indicative



Dibujo:
CORTE PARAGOLPES
SKODA SUPERB COMBI

Escala:
1:1

UNIDADES EN
mm

EE0232-EE1232

Rev.
P1

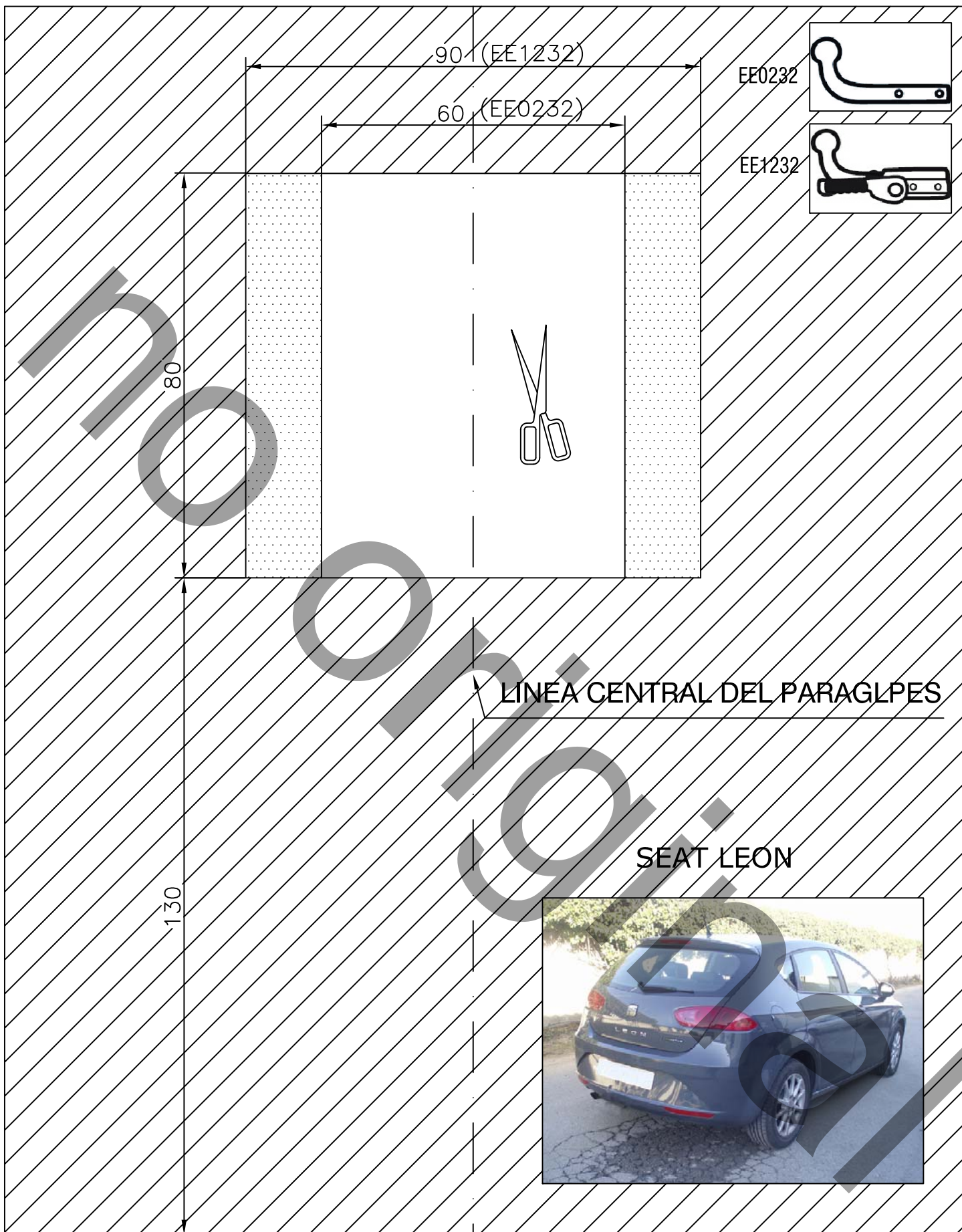

ESP: El corte es orientativo
 UK: The cut is indicative



Dibujo:
 CORTE PARAGOLPES
 SEAT LEON

Escala:
 1:1

UNIDADES EN
 mm

EE0232-EE1232

Rev.
 P1

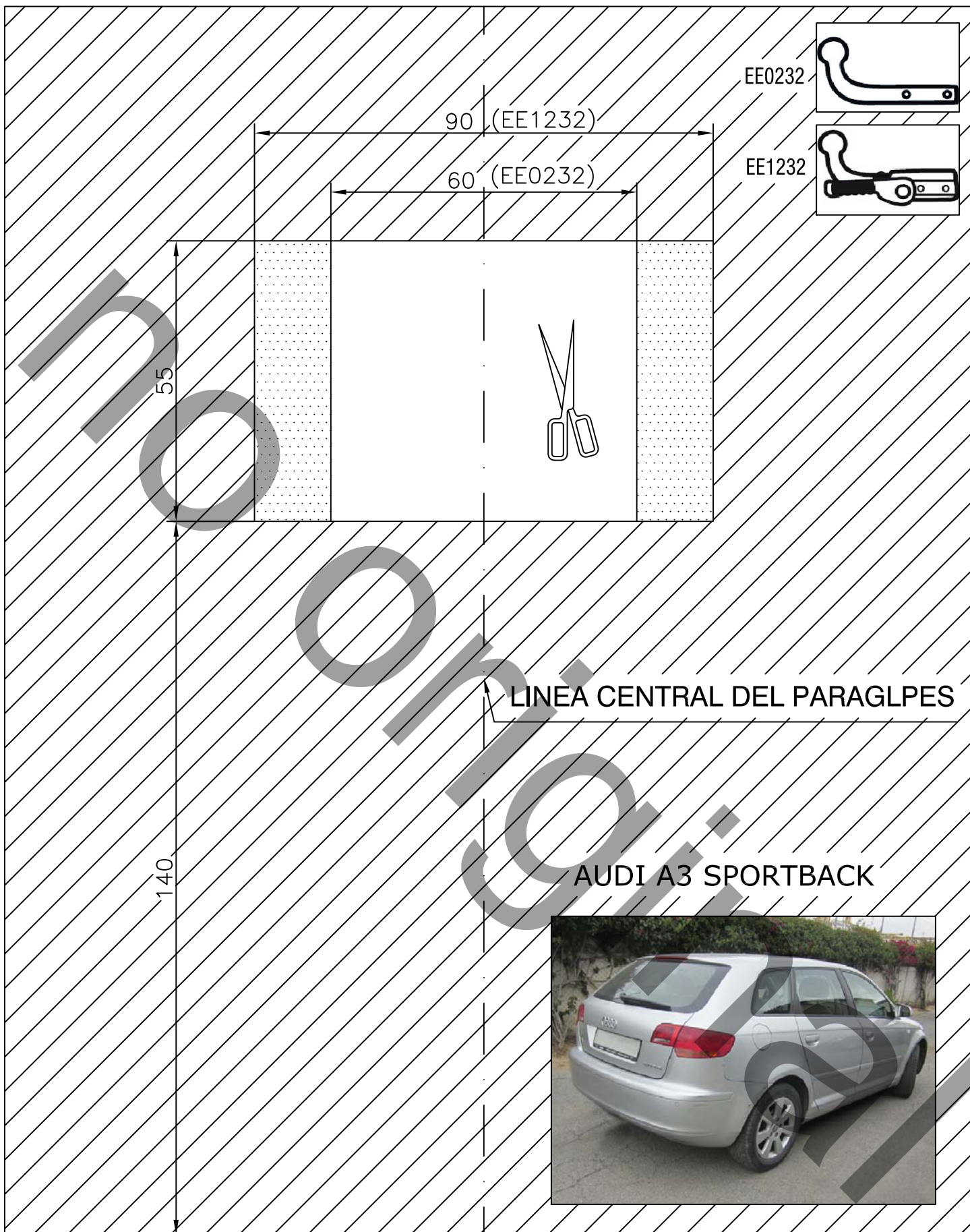

ESP: El corte es orientativo
 UK: The cut is indicative



Dibujo:
 CORTE PARAGOLPES
 AUDI A3 SPORTBACK

Escala:
 1:1

UNIDADES EN
 mm

EE0232-EE1232

Rev.
 P1