

RENAULT CLIO (2005 - ...)

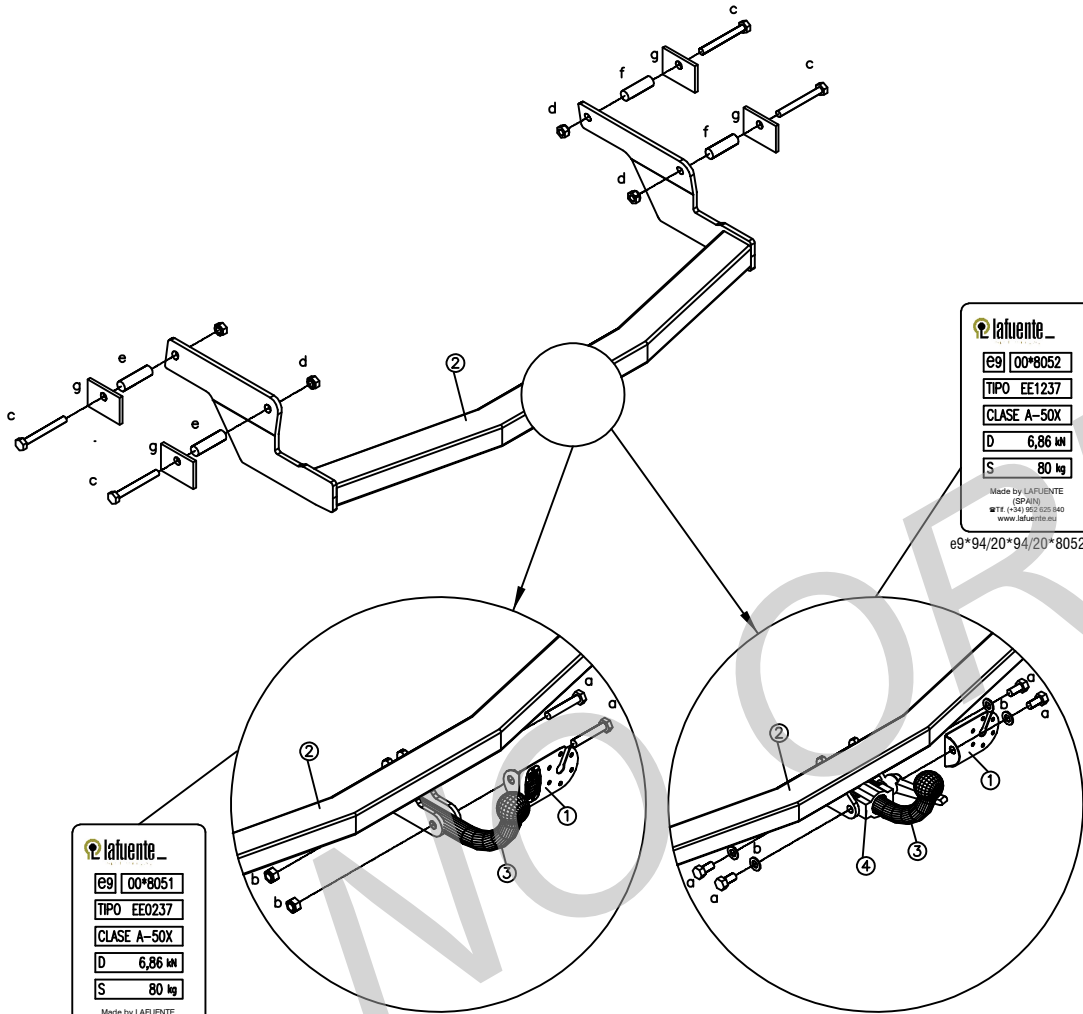

00*8052
TIPO EE1237
CLASE A-50X
D 6,86 kN
S 80 kg
 Made by LAFUENTE (SPAIN)
 Tel: (+34) 952 922 840
 www.lafuente.es

e9*94/20*94/20*8052*00

00*8051
TIPO EE0237
CLASE A-50X
D 6,86 kN
S 80 kg
 Made by LAFUENTE (SPAIN)
 Tel: (+34) 952 922 840
 www.lafuente.es

e9*94/20*94/20*8051*00

M.M.R. 	S 	D
1.200 kg.	80 kg.	6,86 kN



ECE R55

ELEMENTOS DE UNIÓN / CONNECTION COMPONENTS / ELEMENTOS DE UNIÃO
ÉLÉMENTS DE RACCORD / DAZUGEHÖRENDEN TEILEN

BOLA / BALL / BOLA/ ROTULE / KUGEL				VEHÍCULO / VEHICLE / VEÍCULO / VÉHICULE / FAHRZEUG			
				c		4 x M10x90	8.8
a		2 x M12x65	8.8	d		4 x M10 AUTOBLO	8
b		2 x M12	8	e		2 x Ø17 - L=60mm	-
				f		2 x Ø17 - L=55mm	-
a		4 x M12x25	8.8	g		4 x CHAPA ESPECIAL	-
b		4 x M12	-				

Par de apriete para los tornillos/Tightening torque for bolts/Binário de aperto para os parafusos/
 Couple de serrage pour vis/Schrauben Drehmoment

Und.Nm	M6	M8	M10		M12			M14		M16
			1,25	1,25	1,75	1,5	1,25	1,75	1,5	2
8.8	11,3	27,3	54,0	57,0	93,0	97,0	101,0	148,0	159,0	230,0
10.9	16,5	40,1	79,0	83,0	137,0	143,0	149,0	218,0	234,0	320,0
12.9	19,3	46,9	93,0	98,0	160,0	167,0	174,0	255,0	274,0	395,0

HERMANOS SÁNCHEZ-LAFUENTE, S.A.

No asume ningún tipo de responsabilidad por daños causados por usos inadecuados.
 Assumes no responsibility for damage caused by misuse.

Não assume qualquer responsabilidade por danos causados por utilização indevida.

Decline toute responsabilité en cas de dommages causés par une mauvaise utilisation.

Übernimmt keine Verantwortung für Schäden, die durch Missbrauch verursacht werden.

Este documento debe ser presentado en la I.T.V. junto con el certificado de montaje.
 Comprobar en el Certificado de Conformidad (COC) del vehículo las capacidades máximas de arrastre y carga vertical.
 Check the vehicle's documentation for the maximum towing and vertical load capacities.
 Verificar no Certificado de Conformidade do veículo as capacidades máximas de reboque e carga vertical.
 Consultez la carte grise du véhicule pour connaître les capacités maximales de remorquage et de charge verticale.
 Überprüfen Sie die Fahrzeugdokumentation auf die maximale Anhängelast und Stützlast.



RENAULT CLIO (2005 - ...)



EE0237



EE1237

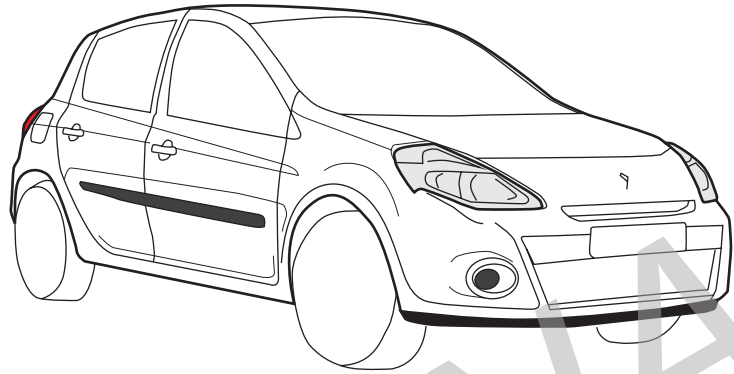

1

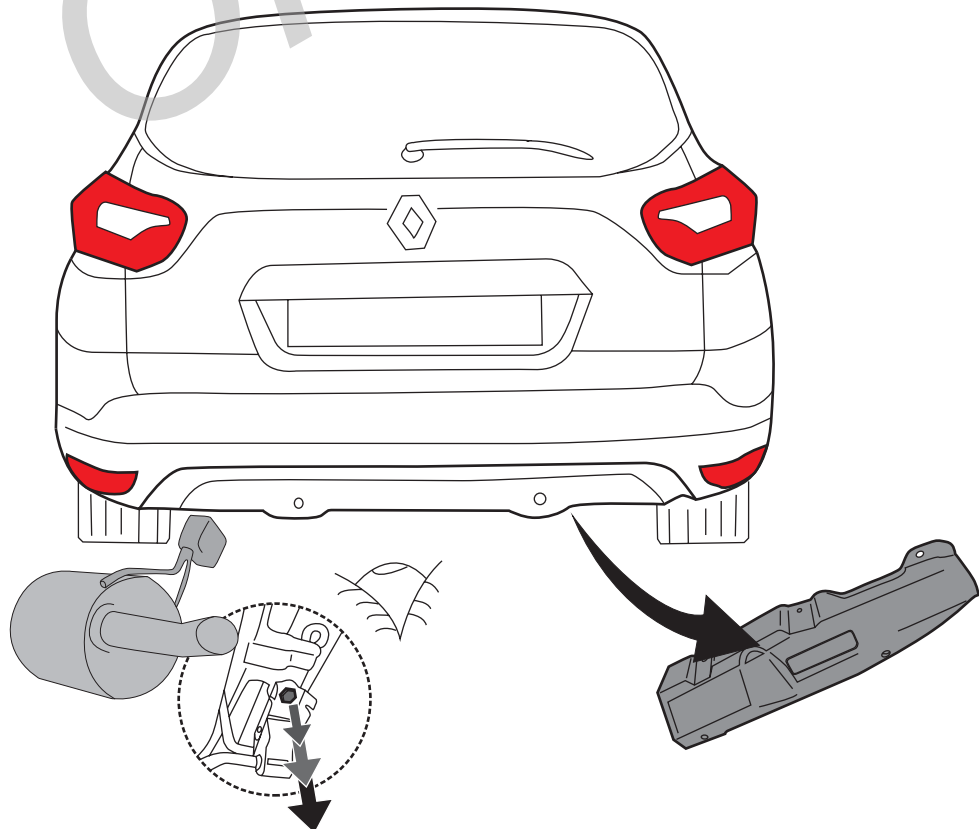

2

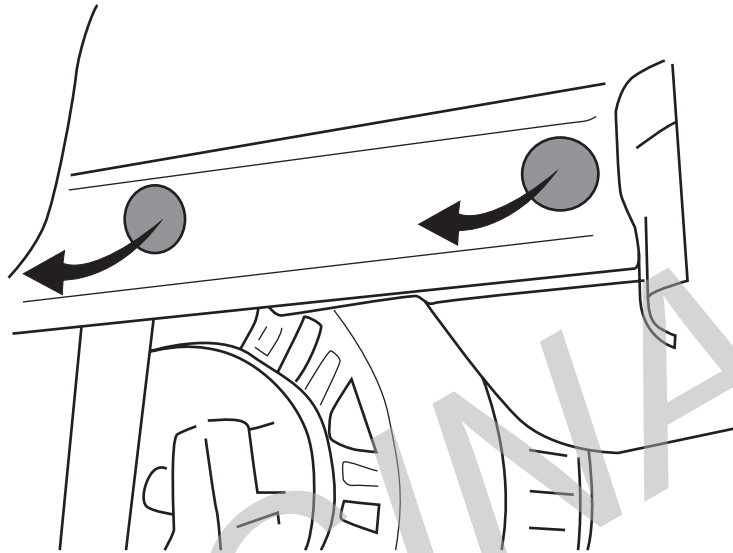
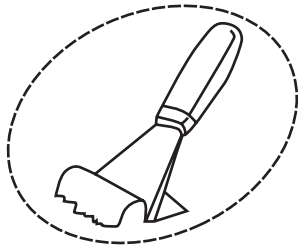
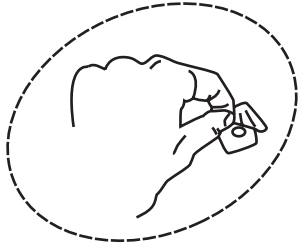
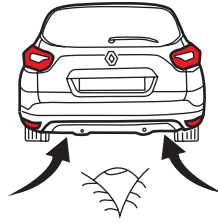

3

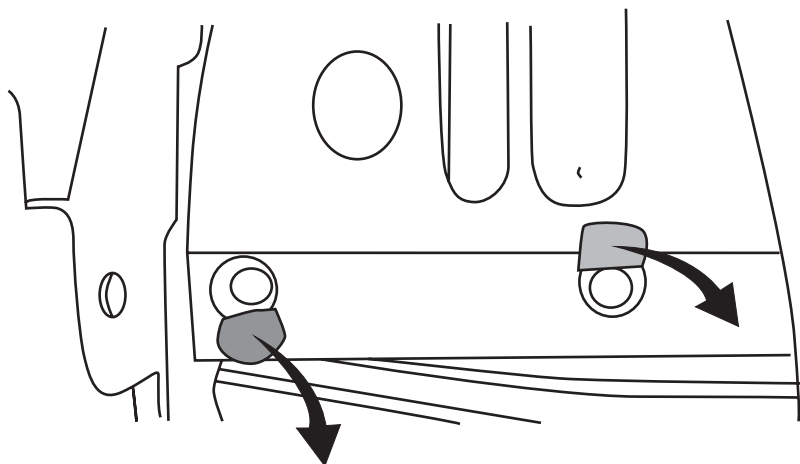
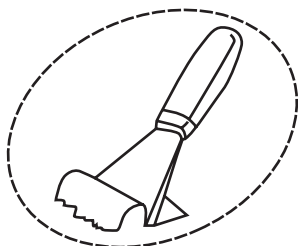
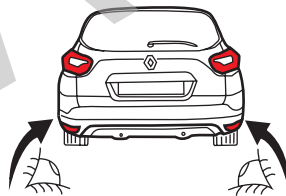

4

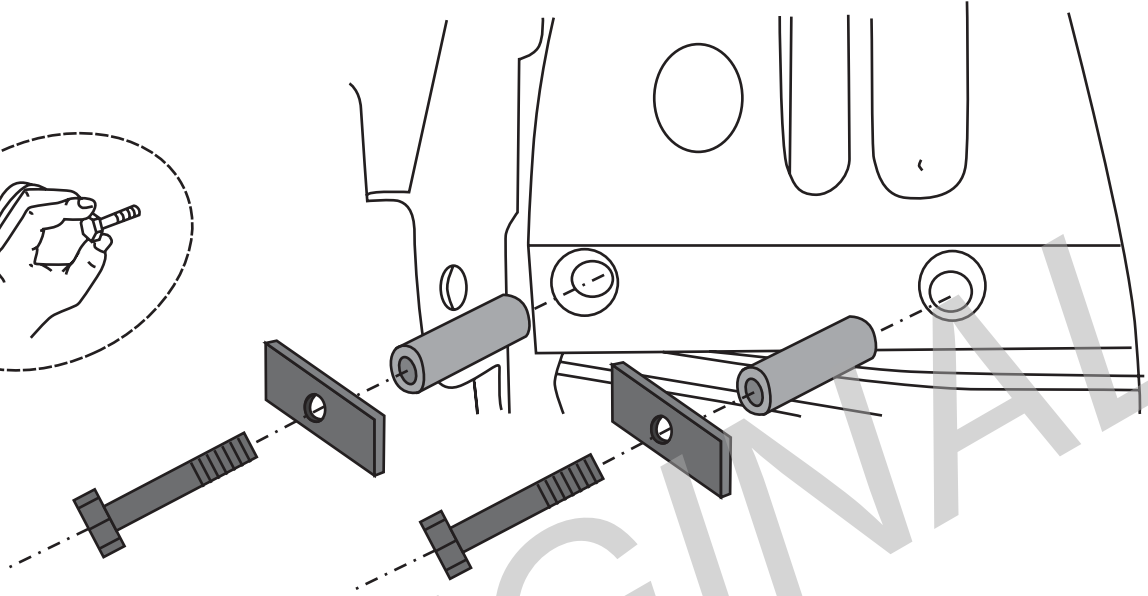
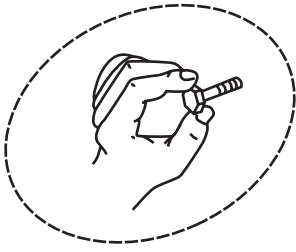
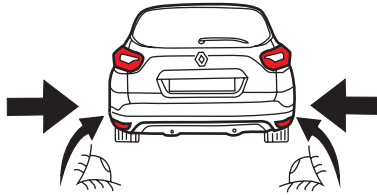

5

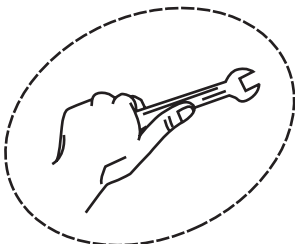
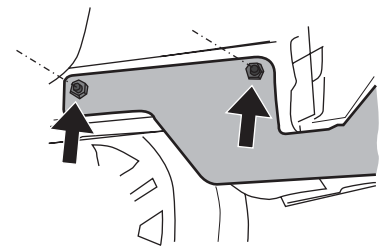
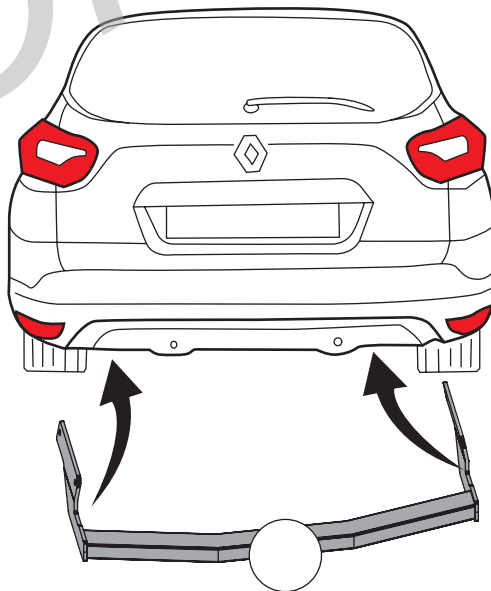
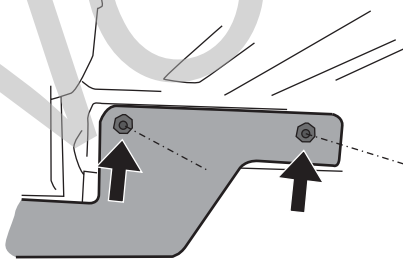

	M6	M8	M10	M12	M14	M16
8.8	10,4Nm	25,0Nm	51,0Nm	87,0Nm	140,0Nm	215,0Nm
10.9	15,5Nm	37,0Nm	75,0Nm	130,0Nm	205,0Nm	310,0Nm
12.9	18,0Nm	43,0Nm	87,0Nm	150,0Nm	240,0Nm	370,0Nm



6

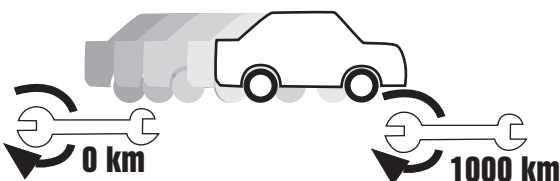
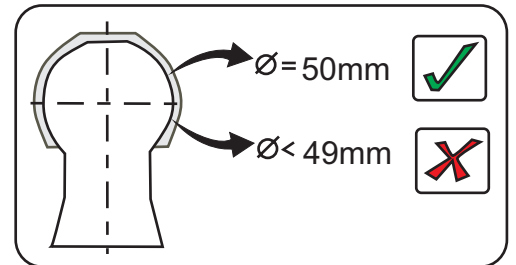
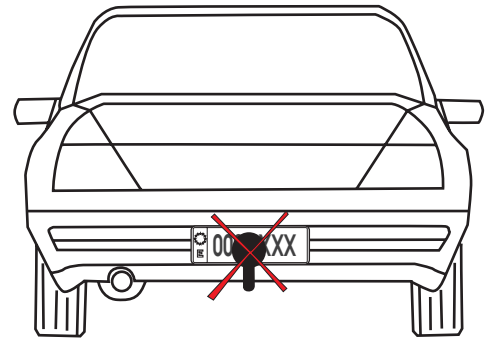
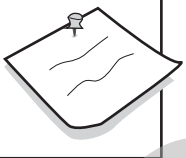
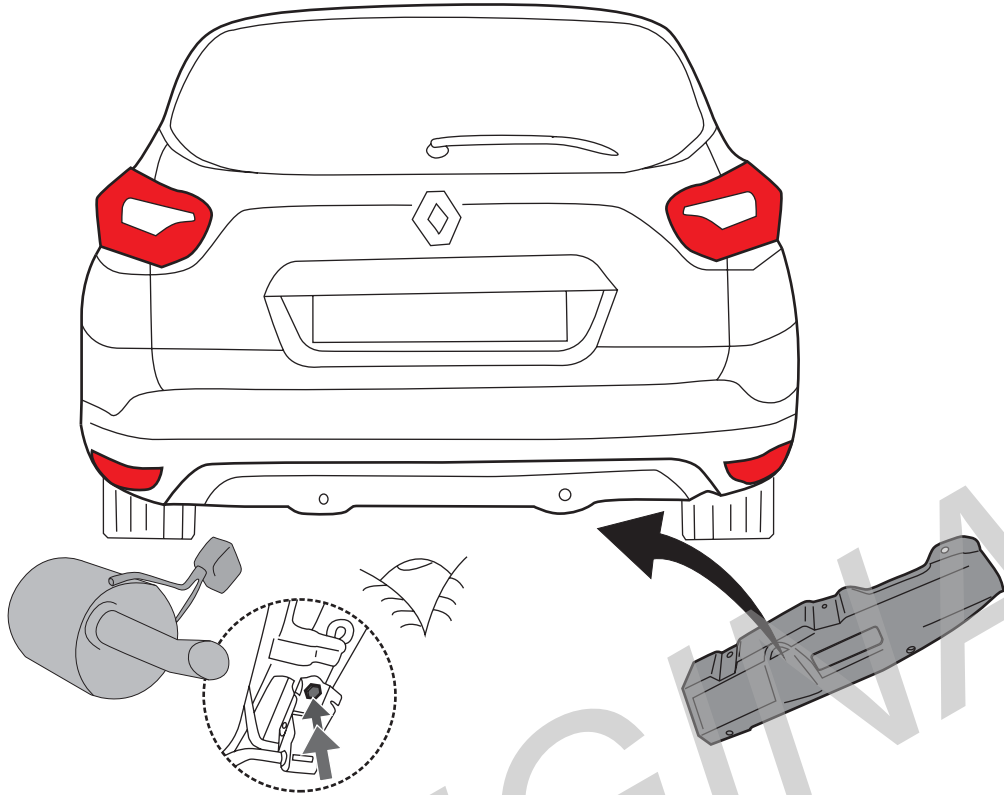

	M6	M8	M10	M12	M14	M16
8.8	10,4Nm	25,0Nm	51,0Nm	87,0Nm	140,0Nm	215,0Nm
10.9	15,5Nm	37,0Nm	75,0Nm	130,0Nm	205,0Nm	310,0Nm
12.9	18,0Nm	43,0Nm	87,0Nm	150,0Nm	240,0Nm	370,0Nm