

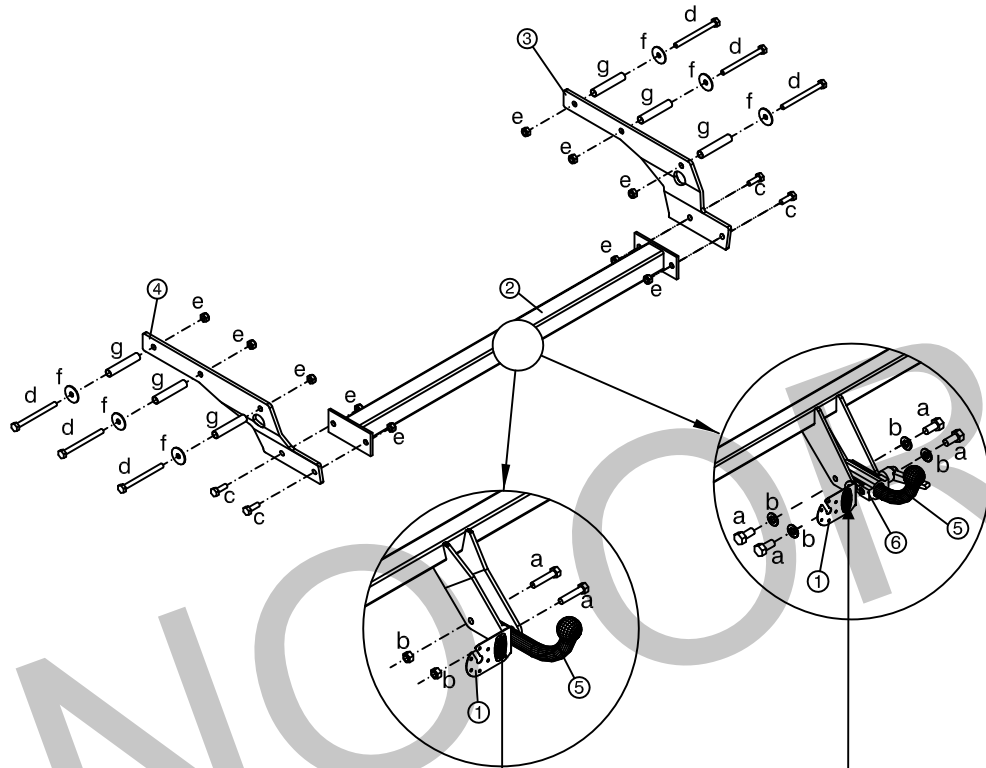

FORD MONDEO FAMILIAR	Nº de homologación Official approval number Prüfung Nr. Nº d'homologation

enganches y remolques

e9	00*2695
TIPO	EE0109
CLASE	A-50X
D	9,59 kN
S	100 kg



Made by LAFUENTE (SPAIN)
Tlf. (+34) 952 625 840
www.lafuente.eu



enganches y remolques



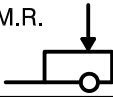







e9	00*2694
TIPO	EE1109
CLASE	A-50X
D	9,59 kN
S	100 kg

Made by LAFUENTE (SPAIN)
Tlf. (+34) 952 625 840
www.lafuente.eu

M.M.R. 	S 	D
1.800 kg.	100 kg.	9,59 kN

Par de apriete para los tornillos Tightening torque for bolts Schrauben Drehmoment Couple de serrage pour vis						
mm	6	8	10	12	14	16
Nm	10	25	55	85	135	200

Enganche homologado según Directiva 94/20 CE.
Hitch officially approved in accordance with Directive 94/20 CE.
Geprüfte Kupplung gemäß Kennzeichen 94/20 CE.
Crochet homologué selon la Directive 94/20 CE.

ELEMENTOS DE UNIÓN / CONNECTION COMPONENTS DAZUGEHÖRENENDEN TEILEN / ÉLÉMENTS DE RACCORD		
BOLA / BALL / KUGEL / BOULE	VEHÍCULO / VEHICLE FAHRZEUG / VÉHICULE	
		
a  2 x M12x65 DIN 931	8.8	c  4 x M10x30 DIN 933 8.8
b  2 x M12 DIN 985	8	d  6 x M10x120 DIN 931 8.8
		e  10 x M10 DIN 985 8
		f  6 x M10 DIN 9021 -
		g  6 x Ø17 L=90mm -
		
a  4 x M12x25 DIN 933	8.8	
b  4 x M12 DIN 127	-	

Este documento debe ser presentado en la I.T.V. junto con el certificado de montaje.
HNOS.SÁNCHEZ-LAFUENTE,S.A. no asume ningún tipo de responsabilidad por daños causados por usos inadecuados.



EE0109



EE1109

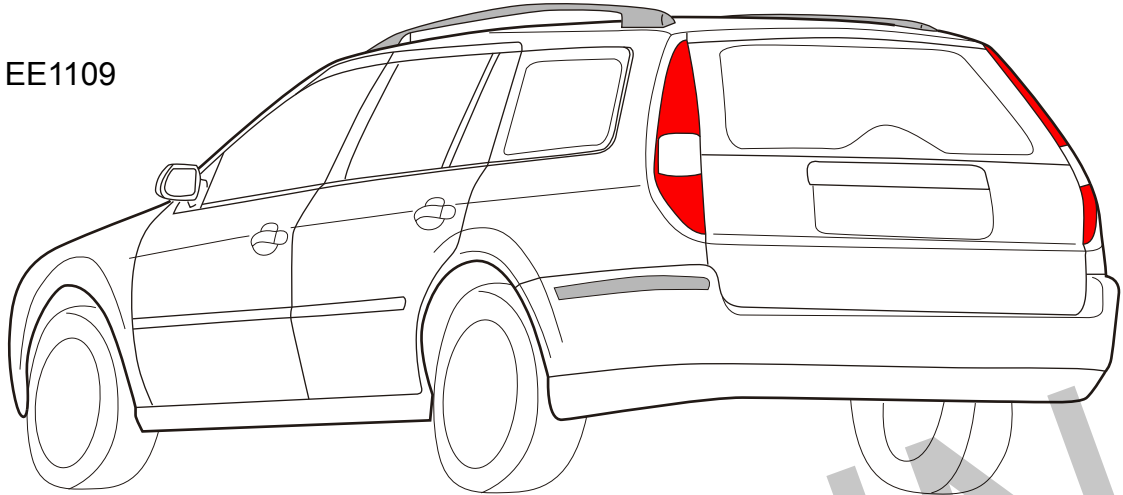

FORD MONDEO FAMILIAR

Instrucciones de montaje - Installation instructions - Notice de montage - Montage- og driftsvejledning

1

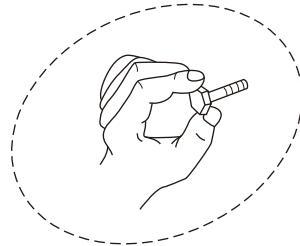
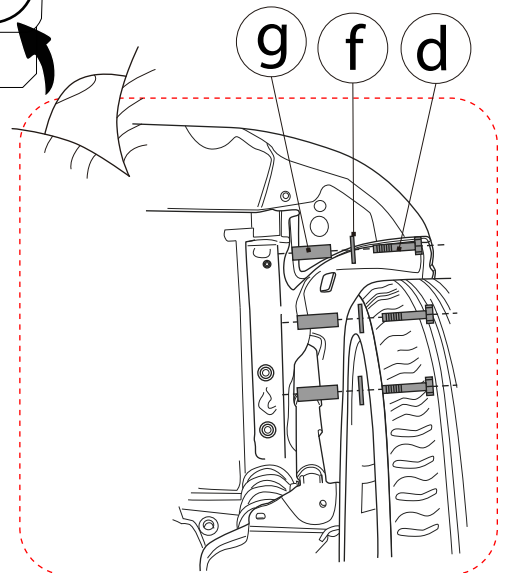
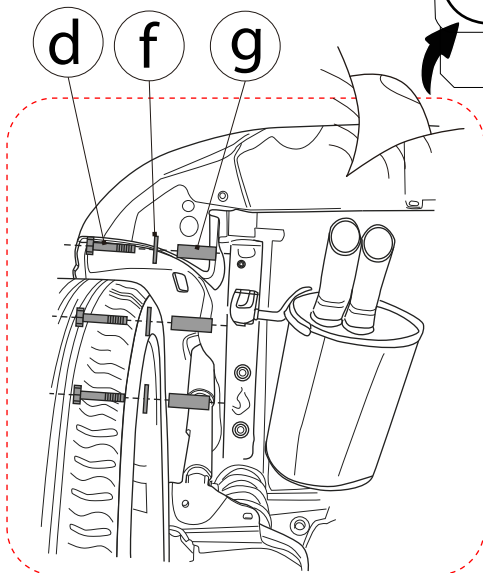
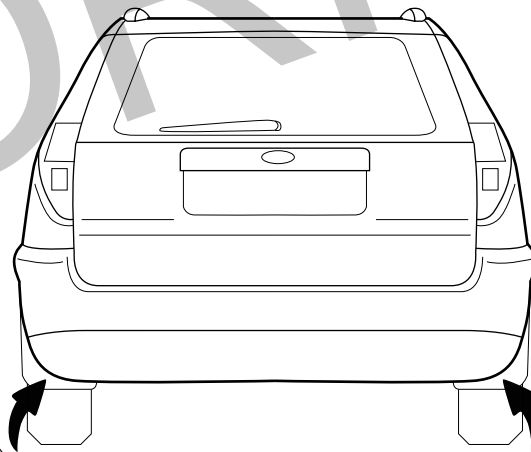

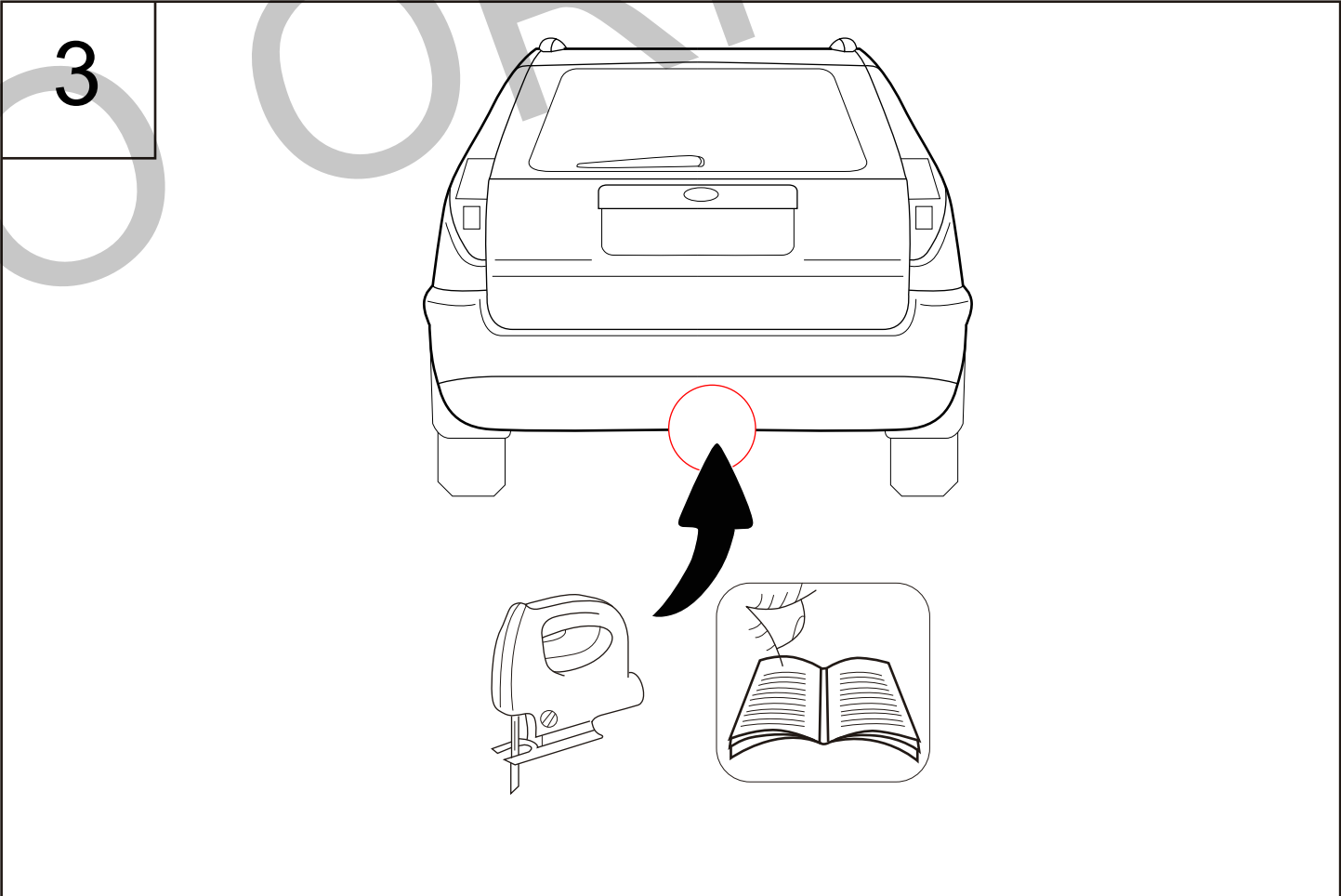
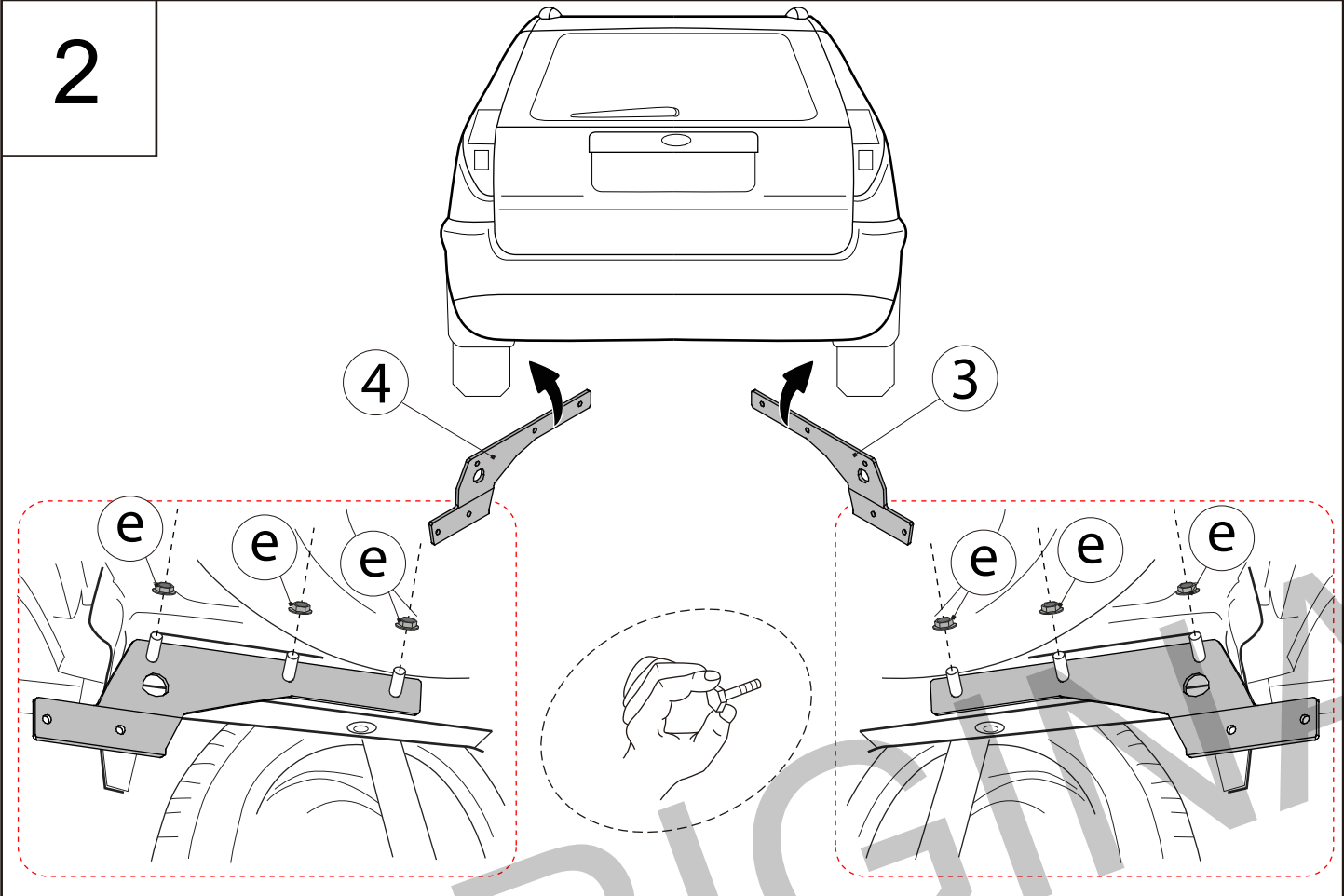

4

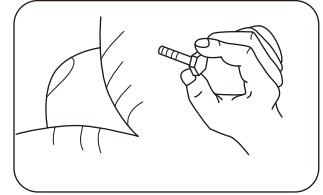
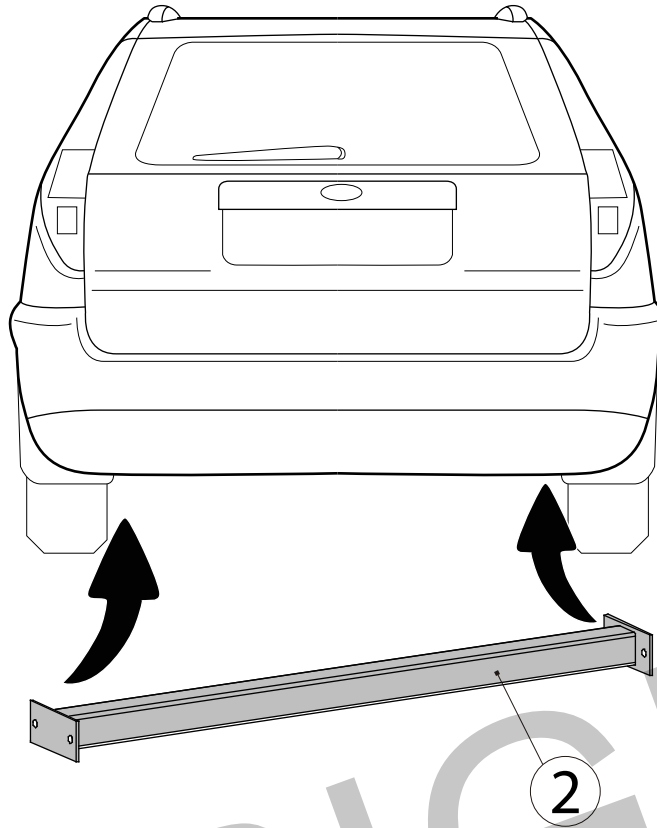
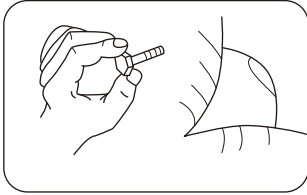

5

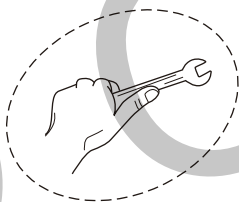

	M6	M8	M10	M12	M14	M16
8.8	10,4Nm	25,0Nm	51,0Nm	87,0Nm	140,0Nm	215,0Nm
10.9	15,5Nm	37,0Nm	75,0Nm	130,0Nm	205,0Nm	310,0Nm
12.9	18,0Nm	43,0Nm	87,0Nm	150,0Nm	240,0Nm	370,0Nm

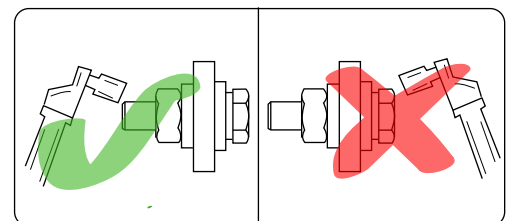
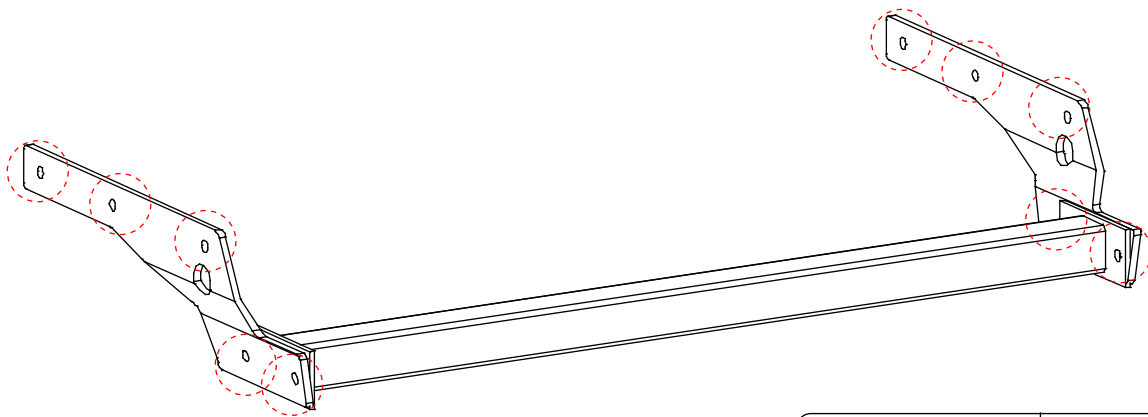

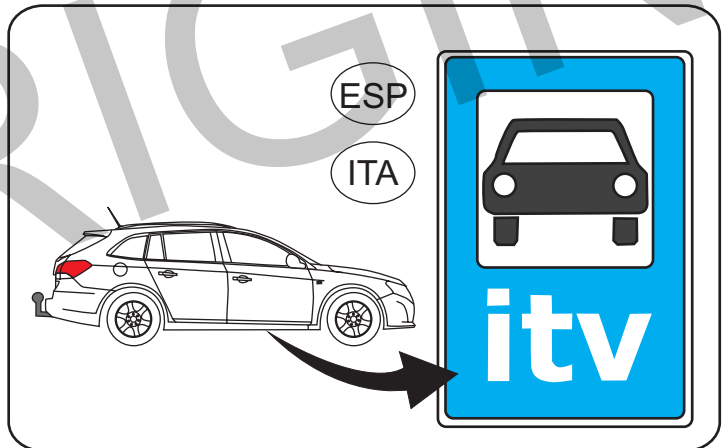
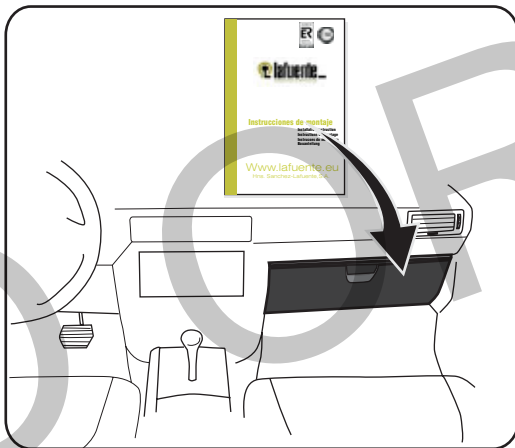
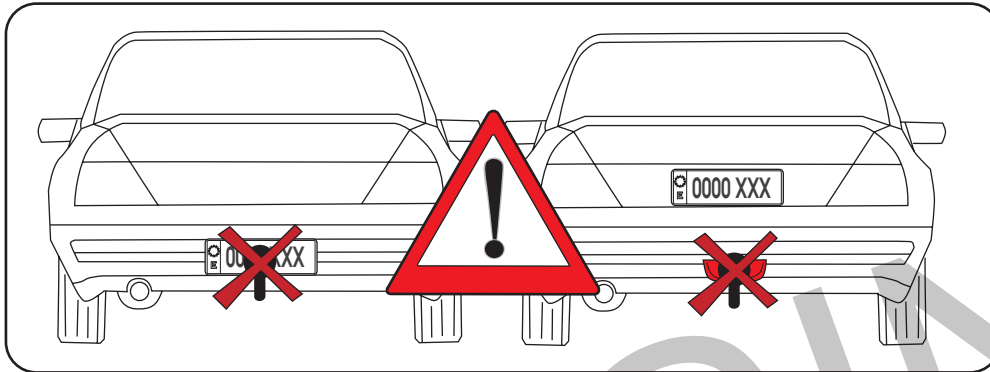
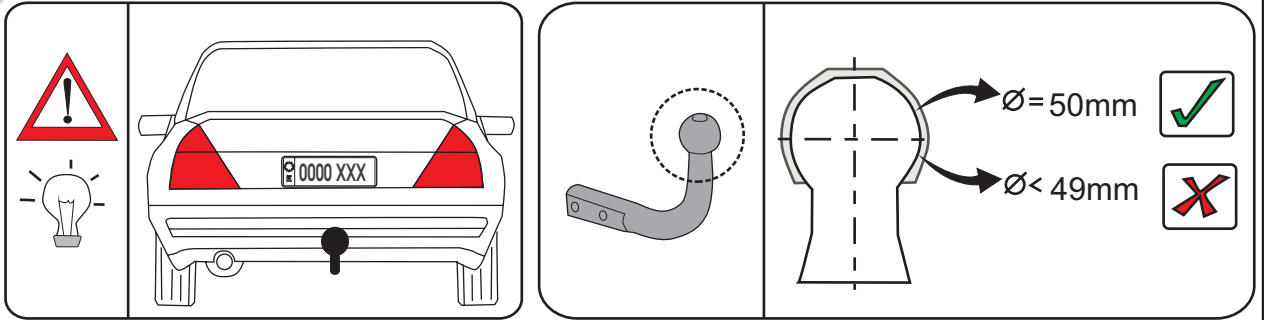
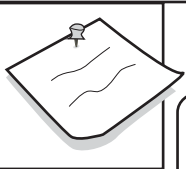

	M6	M8	M10	M12	M14	M16
8.8	10,4Nm	25,0Nm	51,0Nm	87,0Nm	140,0Nm	215,0Nm
10.9	15,5Nm	37,0Nm	75,0Nm	130,0Nm	205,0Nm	310,0Nm
12.9	18,0Nm	43,0Nm	87,0Nm	150,0Nm	240,0Nm	370,0Nm



ESCALA 1:2

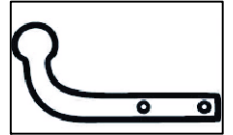

EE0109

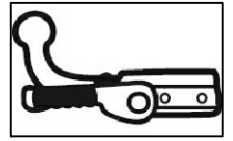

EE1109

90 (EE1109)

60 (EE0109)

105

355

250

LINEA CENTRAL
DE LA CARCASA



ESP: El corte es orientativo
UK: The cut is indicative



Dibujo:
CORTE PARAGOLPES
FORD MONDEO FAMILIAR

Escala:
1:2

UNIDADES EN
mm

EE0109-EE1109

Rev.
P1