

BMW X3
BMW X4

Nº de homologación
Official approval number
Prüfung Nr.
Nº d'homologation

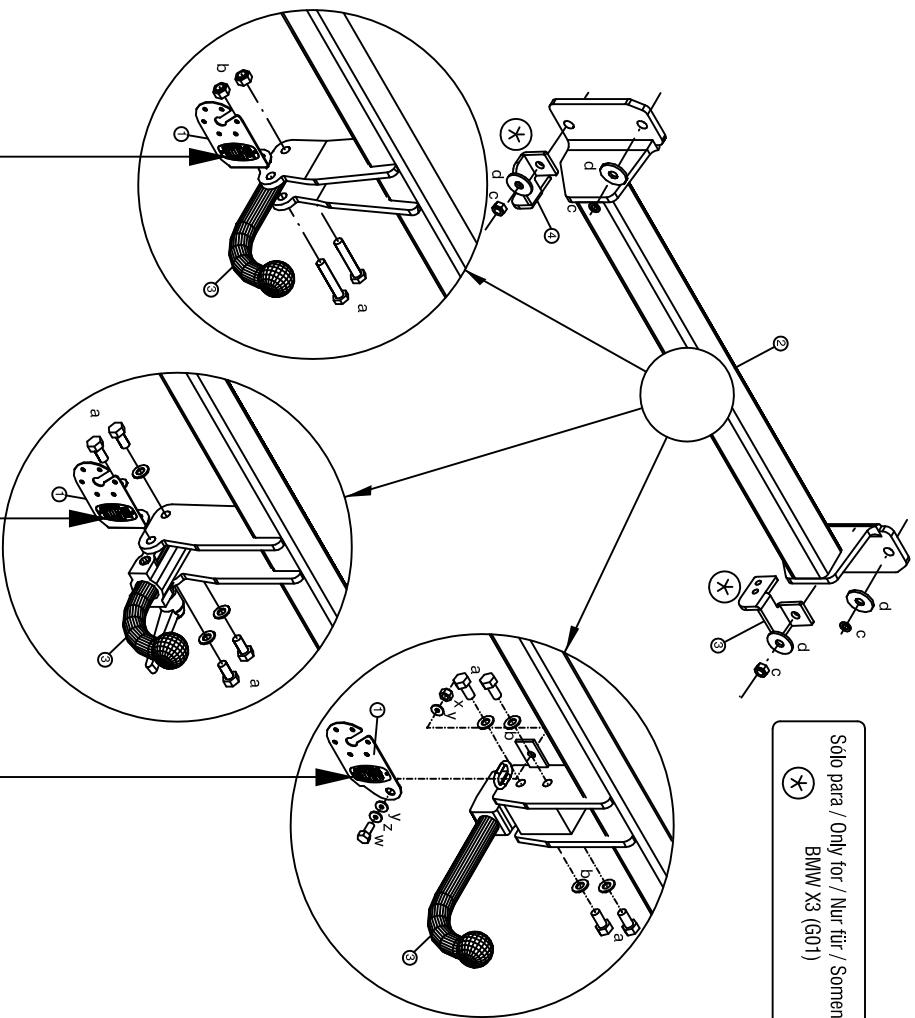

Sólo para / Only for / Nur für / Somente para
(X) BMW X3 (G01)

Lafuente
MAGNUS LAUFUENTE
WITTE, CALVAZCOZ DE ALBA
41010 SAN JUAN DE LOS RIOS
SEVILLA

E9 SSR - 01 2104
TIPO E03385
CLASE A-50X
D 12,60 kN
S 100 kg

E9 SSR-01 2104 Rev01

Lafuente
MAGNUS LAUFUENTE
WITTE, CALVAZCOZ DE ALBA
41010 SAN JUAN DE LOS RIOS
SEVILLA



E9 SSR - 01 2106
TIPO E1385
CLASE A-50X
D 12,60 kN
S 100 kg

E9 SSR-01 2106 Rev01

Lafuente
MAGNUS LAUFUENTE
WITTE, CALVAZCOZ DE ALBA
41010 SAN JUAN DE LOS RIOS
SEVILLA



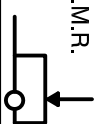

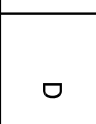







E9 SSR - 01 2105
TIPO E4385
CLASE A-50X
D 12,60 kN
S 100 kg

E9 SSR-01 2105 Rev01

M.M.R.			
2.450 kg.	100 kg.	12,60 kN	

Par de apriete para los tornillos Tightening torque for bolts Schrauben Drehmoment Couple de serrage pour vis	
mm	6 8 10 12 14 16
Nm	10 25 55 85 135 200

Enganche homologado según Reglamento nº 55 CEPE
Hitch officially approved in accordance with Regulation nº 55 CEPE
Geprüfte Kupplung gemäß Reglement nº 55 CEPE
Crochet homologué selon la Règlementation nº 55 CEPE

ELEMENTOS DE UNIÓN / CONNECTION COMPONENTS DAZUGEHÖRENDE TEILEN / ÉLÉMENTS DE RACCORD		VEHÍCULO / VEHICLE FAHRZEUG / VÉHICULE	
BOLA / BALL / KUGEL / BOULE			
a	 2 x M12x65 DIN 931	8,8	c  4 x M12 DIN 125
b	 2 x M12 DIN 985	8	d  4 x M12 DIN 127
BOLA / BALL / KUGEL / BOULE			
a	 4 x M12x25 DIN 933	8,8	w  1 x M10x30 DIN 933
b	 4 x M12 DIN 125	-	x  1 x M10 DIN 985
BOLA / BALL / KUGEL / BOULE			
a	 4 x M12x 25 DIN 933	8,8	y  2 x M10 DIN 125
b	 4 x M12 DIN 127	-	z  1 x M10 DIN 2093

Este documento debe ser presentado en la I.T.V. junto con el certificado de montaje.

HINOS.SÁNCHEZ-LAFUENTE,S.A. no asume ningún tipo de responsabilidad por daños causados por usos inadecuados.

Nº Rev: 03 Aprobado: 21-02-2018

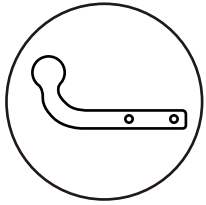

EE0385

BMW X3

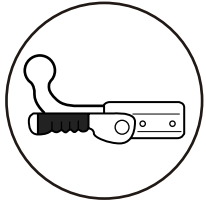
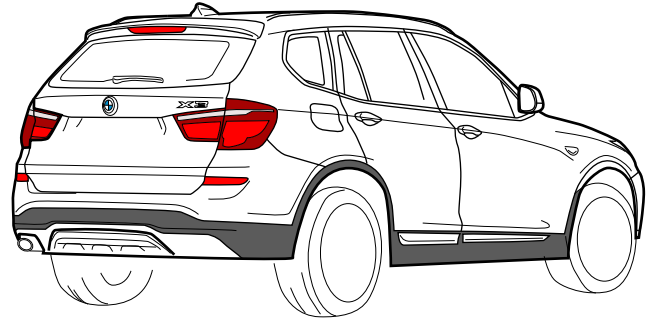

EE1385

BMW X4

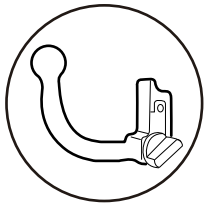
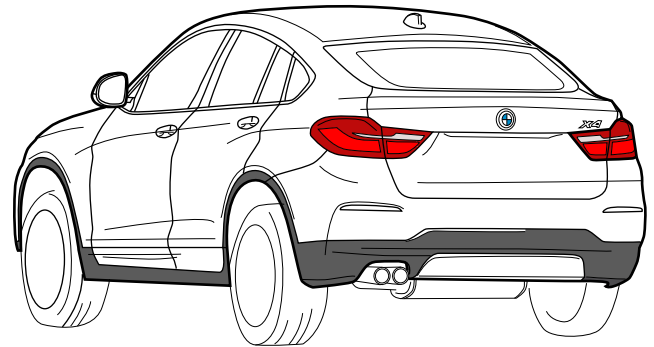

EE4385

1

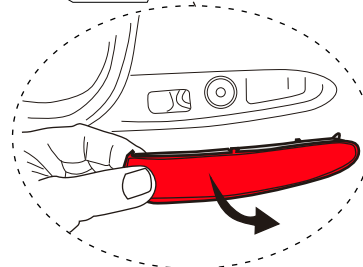
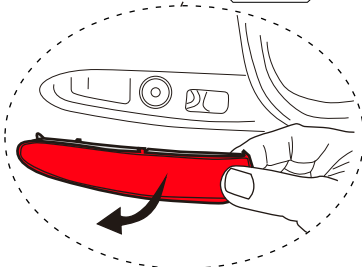
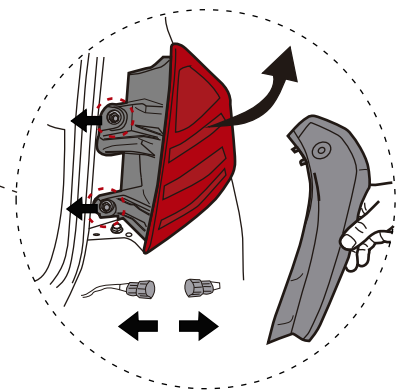
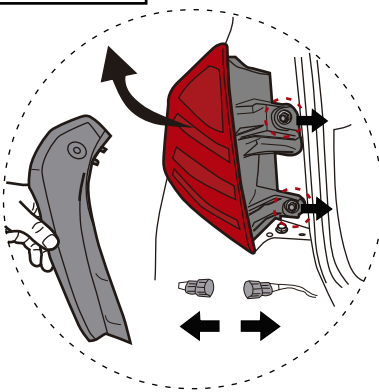

2

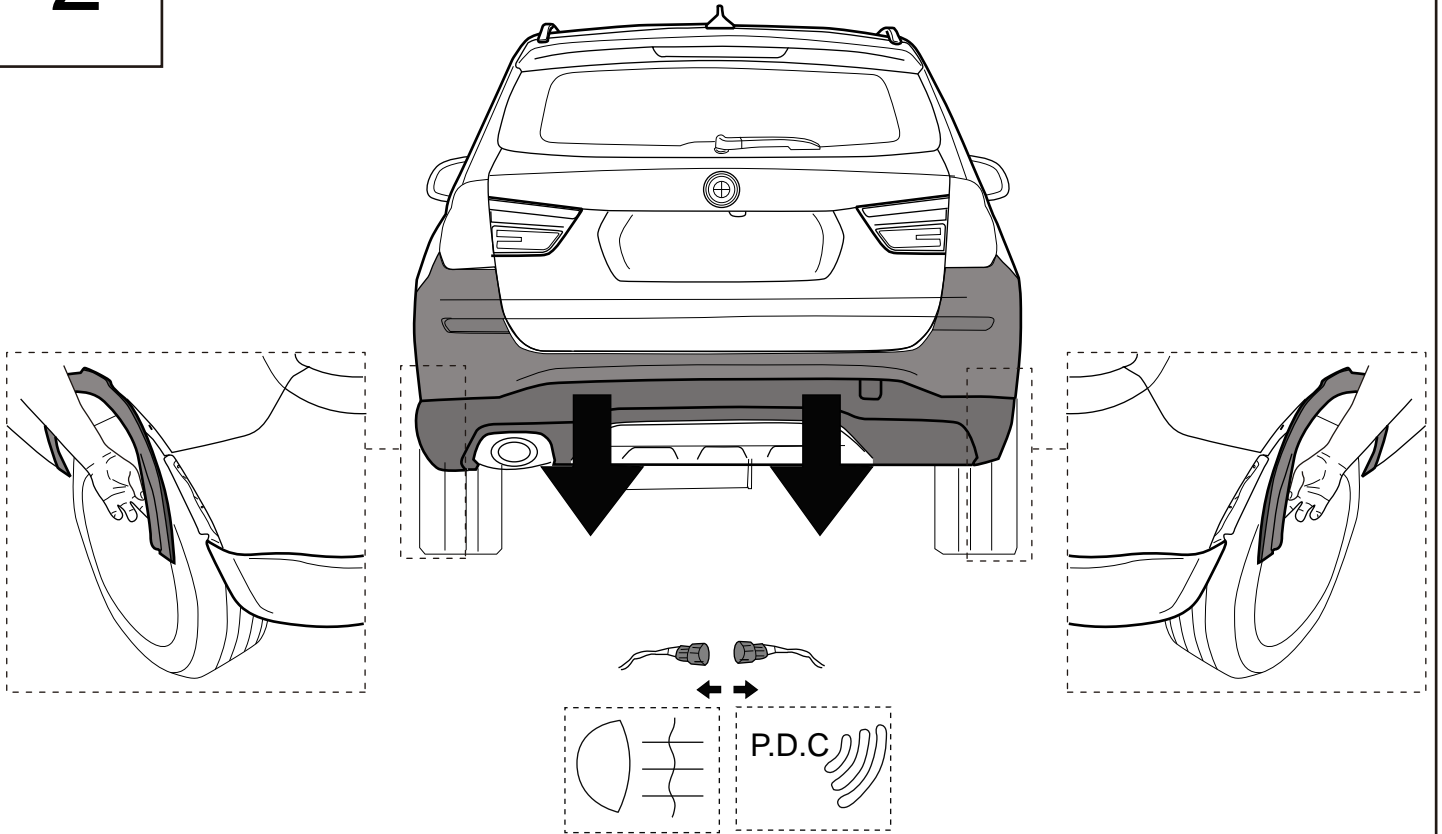

3

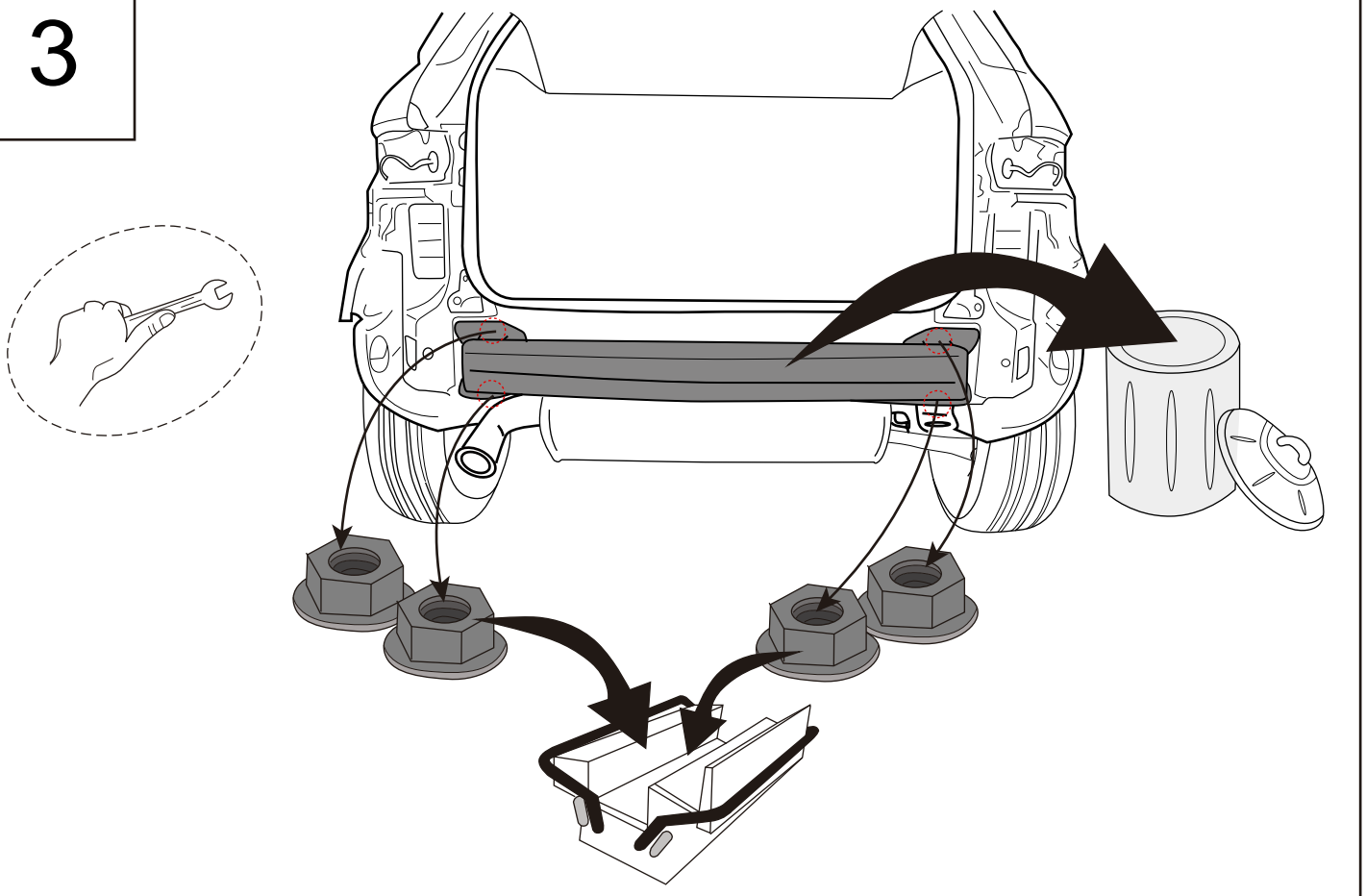

4



**BMW X3 (F25)
BMW X4**

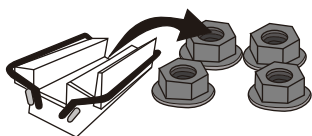
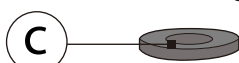
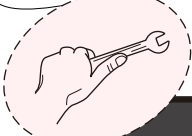
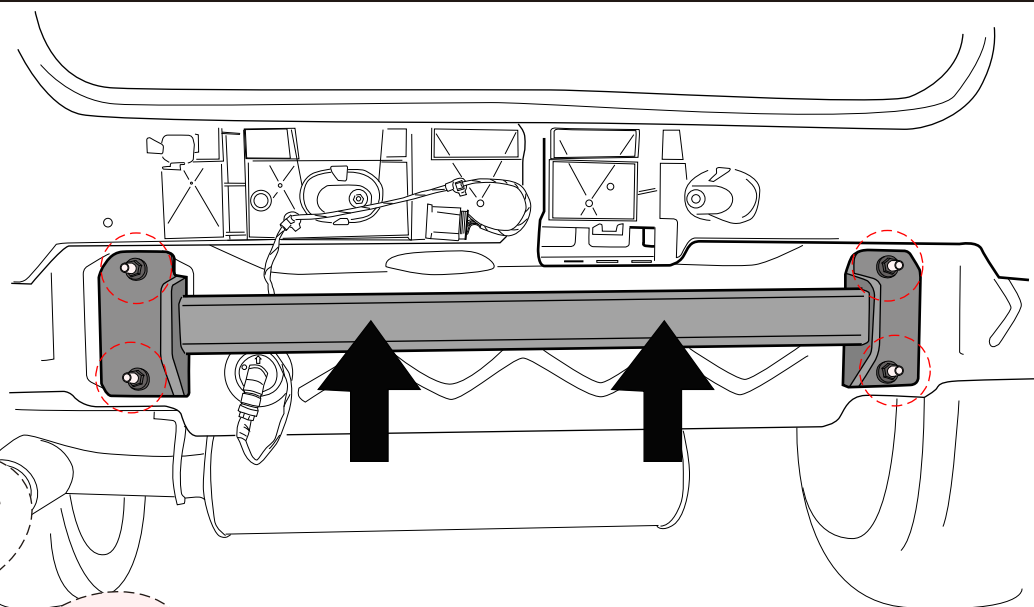

	M6	M8	M10	M12	M14	M16
8.8	10,4Nm	25,0Nm	51,0Nm	87,0Nm	140,0Nm	215,0Nm
10.9	15,5Nm	37,0Nm	75,0Nm	130,0Nm	205,0Nm	310,0Nm
12.9	18,0Nm	43,0Nm	87,0Nm	150,0Nm	240,0Nm	370,0Nm

5



BMW X3 (G01)

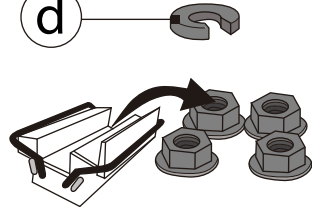
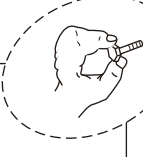
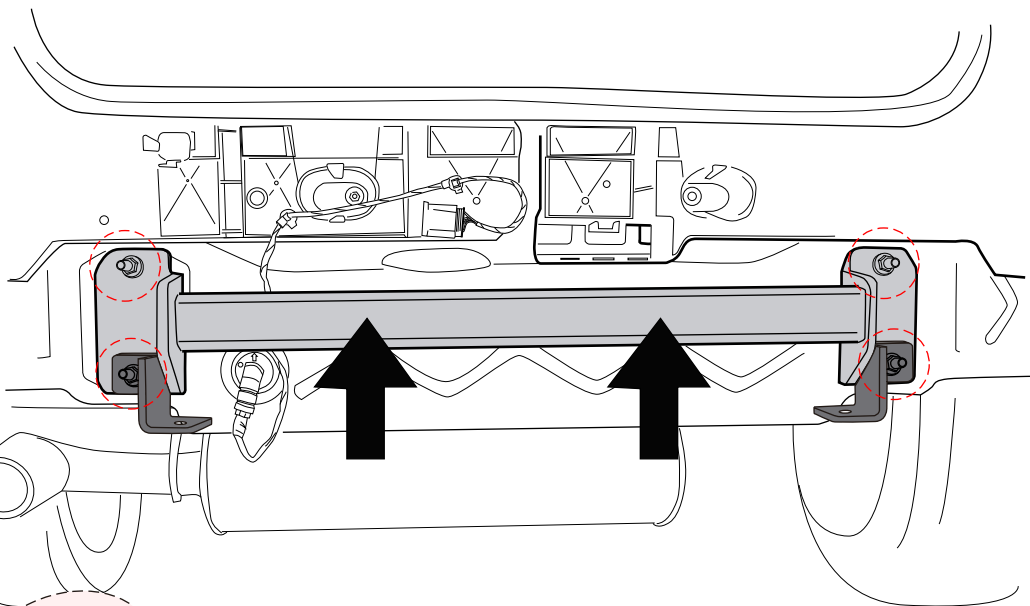

	M6	M8	M10	M12	M14	M16
8.8	10,4Nm	25,0Nm	51,0Nm	87,0Nm	140,0Nm	215,0Nm
10.9	15,5Nm	37,0Nm	75,0Nm	130,0Nm	205,0Nm	310,0Nm
12.9	18,0Nm	43,0Nm	87,0Nm	150,0Nm	240,0Nm	370,0Nm

6

BMW X3 (G01)

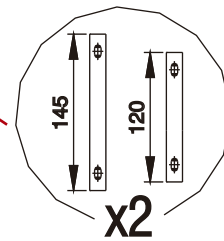
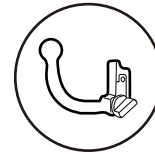
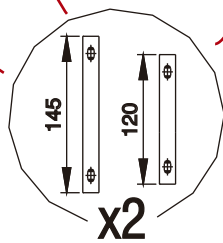
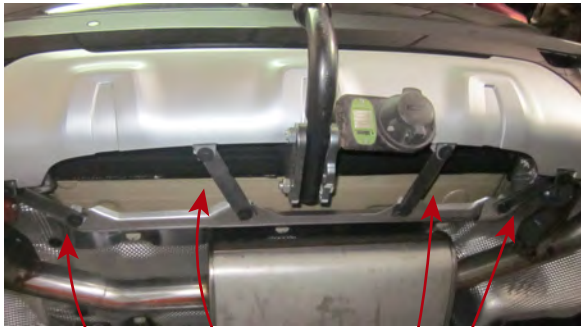
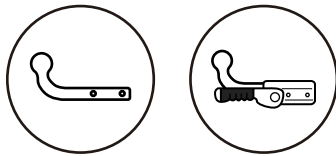

7



BMW X3 (F25)

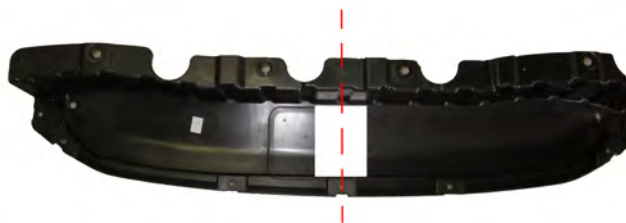

BMW X4

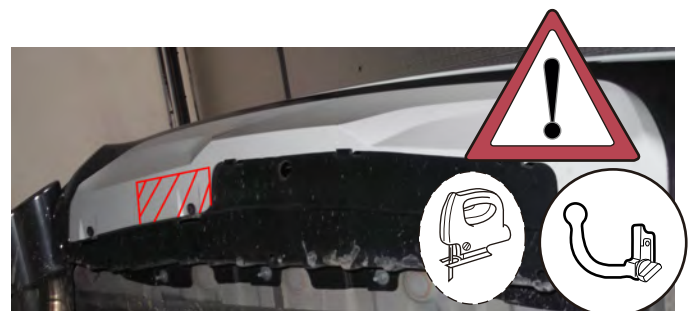

8

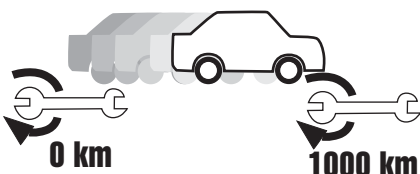
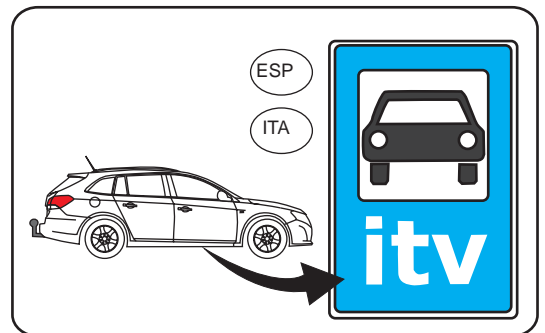
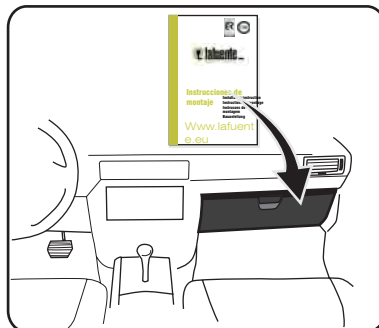
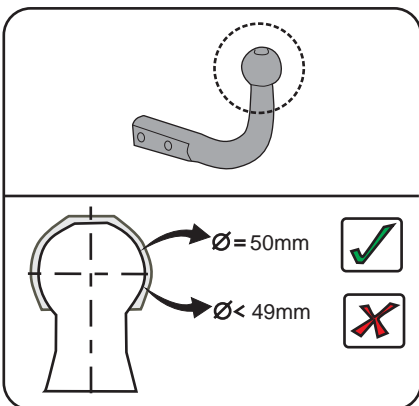
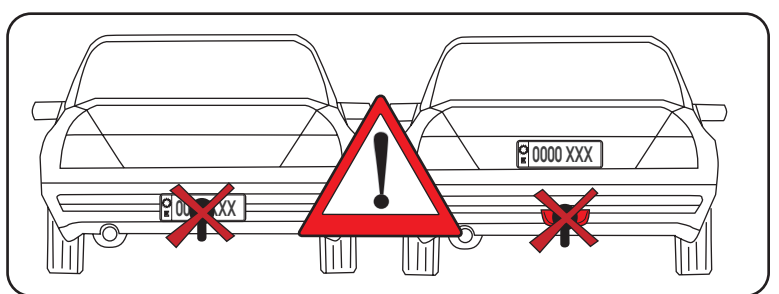
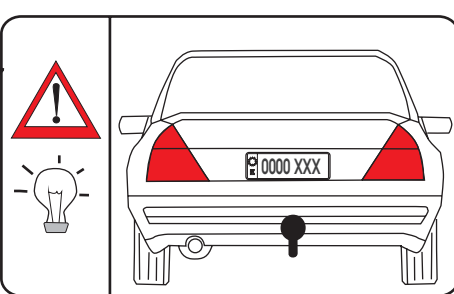
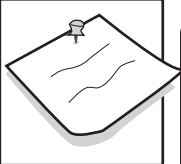
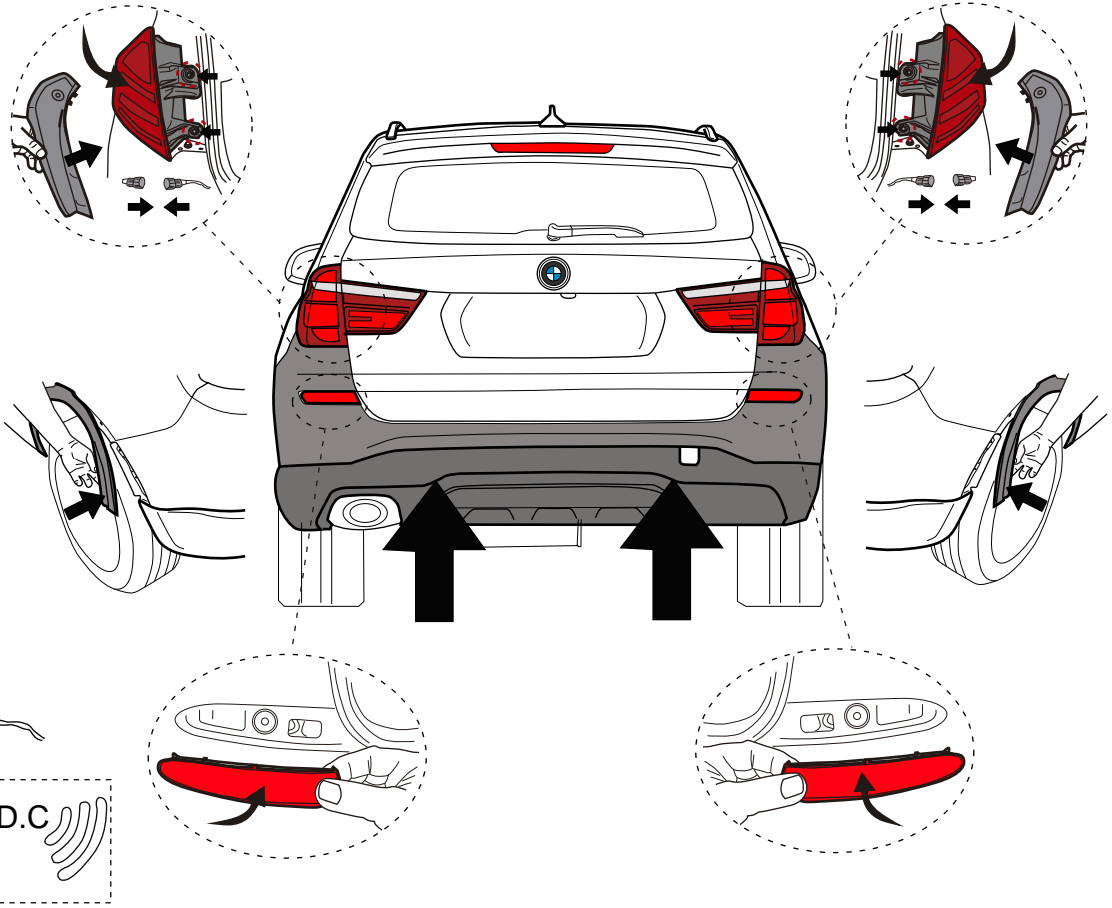

	M6	M8	M10	M12	M14	M16
8.8	10,4Nm	25,0Nm	51,0Nm	87,0Nm	140,0Nm	215,0Nm
10.9	15,5Nm	37,0Nm	75,0Nm	130,0Nm	205,0Nm	310,0Nm
12.9	18,0Nm	43,0Nm	87,0Nm	150,0Nm	240,0Nm	370,0Nm