

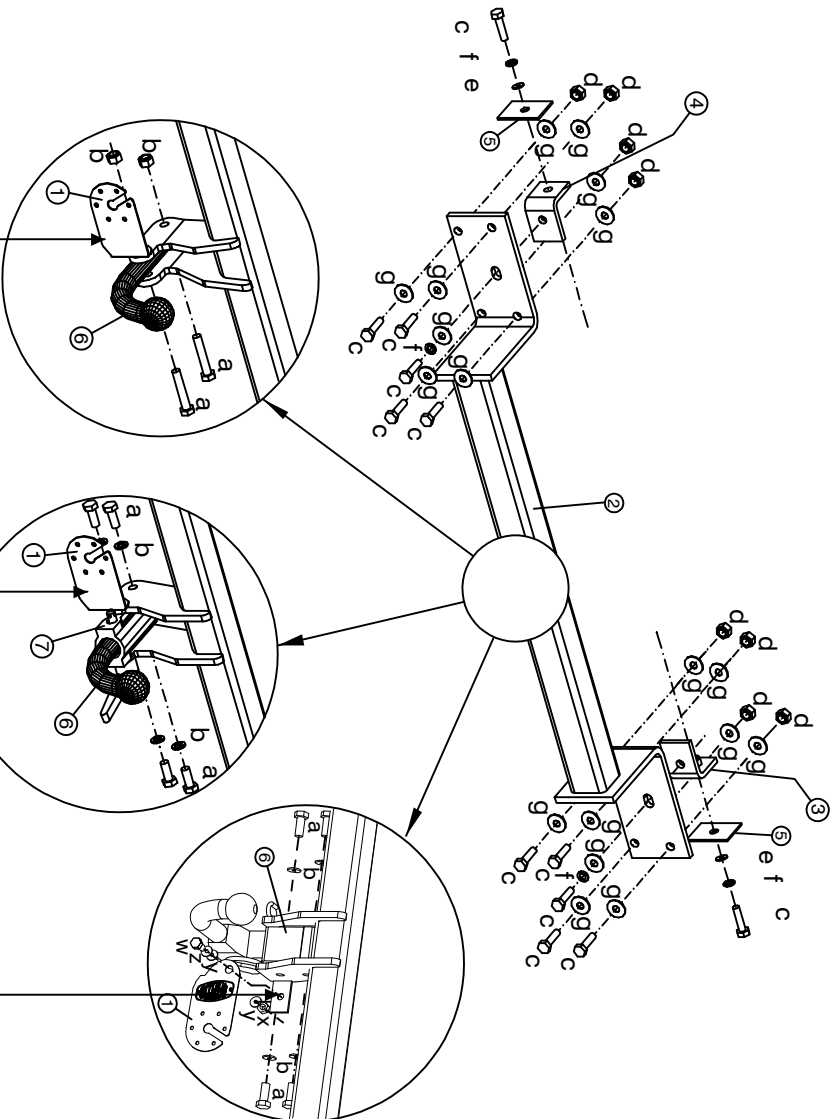

**MERCEDES**  
CLASE A W176  
CLASE B W246  
GLA  
CLA / CLA Shooting Brake  
INFINITI Q30 + QX30

Nº de homologación  
Official approval number  
Prüfung Nr.  
Nº d'homologation

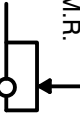

M.M.R.			D
1.800 kg.	80 kg.	9,41 kN	

Par de apriete para los tornillos Tightening torque for bolts Schrauben Drehmoment Couple de serrage pour vis						
mm	6	8	10	12	14	16
Nm	10	25	55	85	135	200

Enganche homologado según R55 / Directiva 94/20 CE.  
Hitch officially approved in accordance with R55 / Directive 94/20 CE.  
Geprüfte Kupplung gemäß Kennzeichen R55 / 94/20 CE.  
Crochet homologué selon la Directive R55 / 94/20 CE.

ELEMENTOS DE UNIÓN / CONNECTION COMPONENTS DAZUGEHÖRENDE TEILEN / ÉLÉMENTS DE RACCORD		VEHÍCULO / VEHICLE FAHRZEUG / VÉHICULE	
<b>BOLA / BALL / KUGEL / BOULE</b>			
			
a	2 x M12x65 DIN 931	8,8	c
b	2 x M12 DIN 985	8	d
			e
a	4 x M12x25 DIN 933	8,8	f
b	4 x M12 DIN 127	-	g
			w
			x
			y
			z

Made by LAFUENTE  
EN 17176 (SPAIN) IS 1430  
www.lafuente.eu

**E9** 5SR-01 2288

TIPO EEC0415 D 9,41 kN  
CLASE A-50X S 80 kg

Made by LAFUENTE  
EN 17176 (SPAIN) IS 1430  
www.lafuente.eu

**E9** 5SR-01 2289

TIPO EEC1415 D 9,41 kN  
CLASE A-50X S 80 kg

Made by LAFUENTE  
EN 17176 (SPAIN) IS 1430  
www.lafuente.eu

**E9** 5SR-01 2290

TIPO EEC4415 D 9,41 kN  
CLASE A-50X S 80 kg

Este documento debe ser presentado en la I.T.V. junto con el certificado de montaje.  
HNOS. SÁNCHEZ-LAFUENTE, S.A. no asume ningún tipo de responsabilidad por daños causados por usos inadecuados.  
Nº Rev: 11 Aprobado: 19-10-2018



# MERCEDES

## CLASE A / B / GLA / CLA/CLA Shooting Brake

# INFINITI Q30 + Q30S + QX30

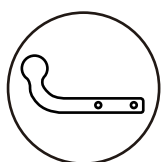

EE0415



EE1415

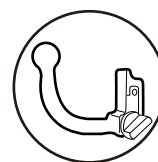

EE4415

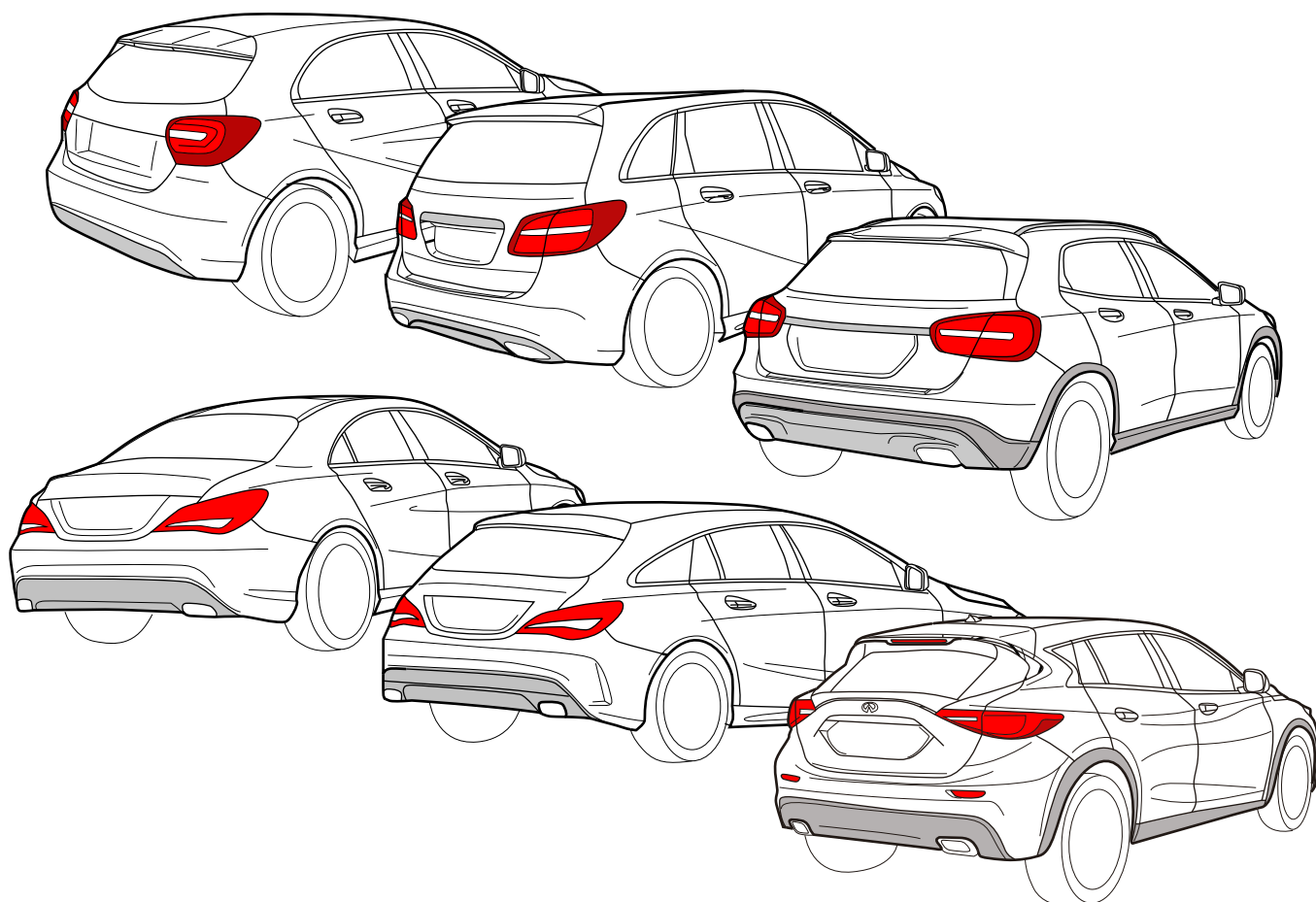

Instrucciones de montaje - Installation instructions - Notice de montage - Montage- og driftsvejledning



1

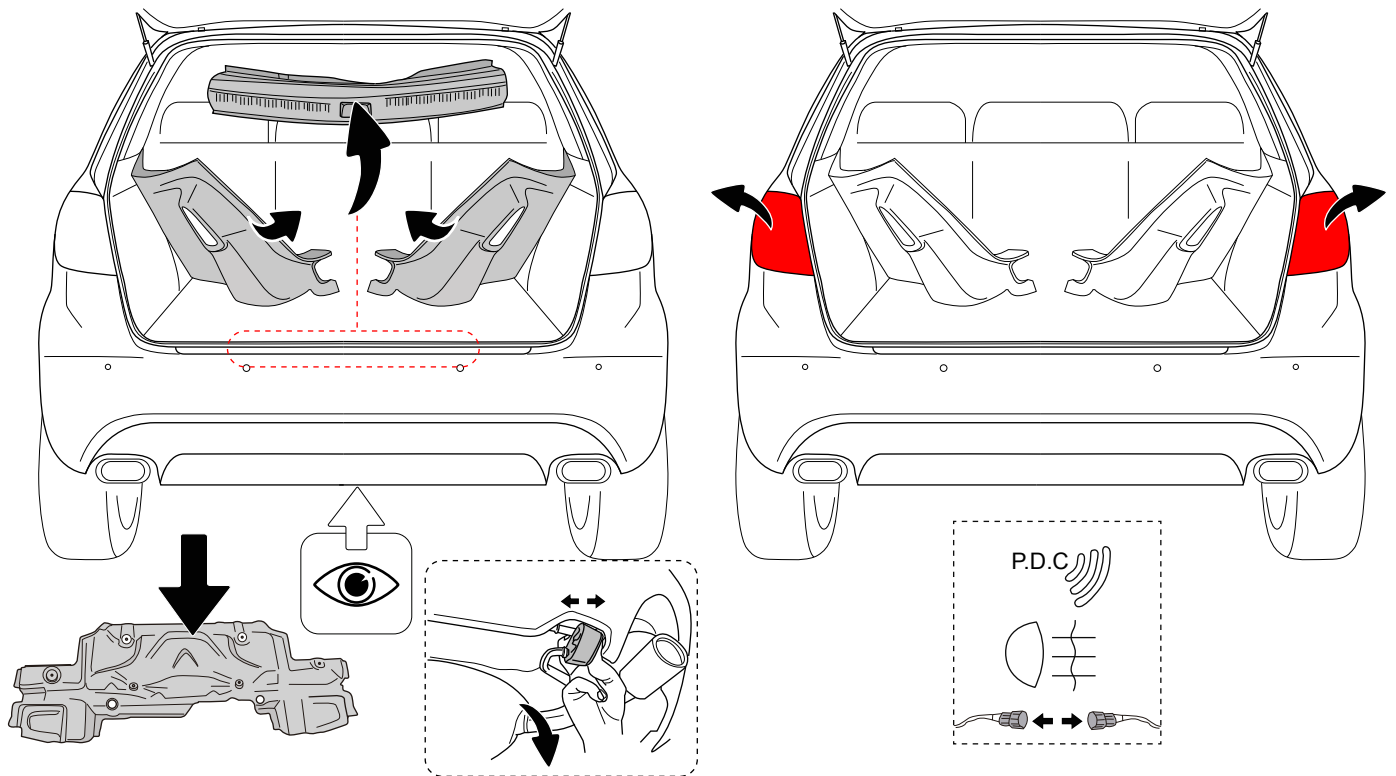

## MERCEDES CLA/CLA Shooting Brake

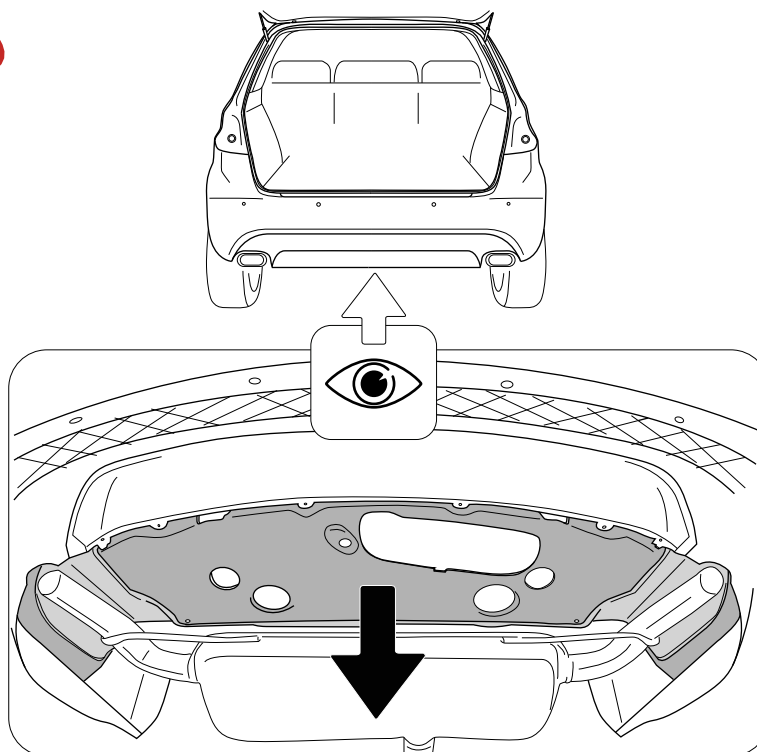

2



**MERCEDES  
GLA**

**INFINITI Q30**

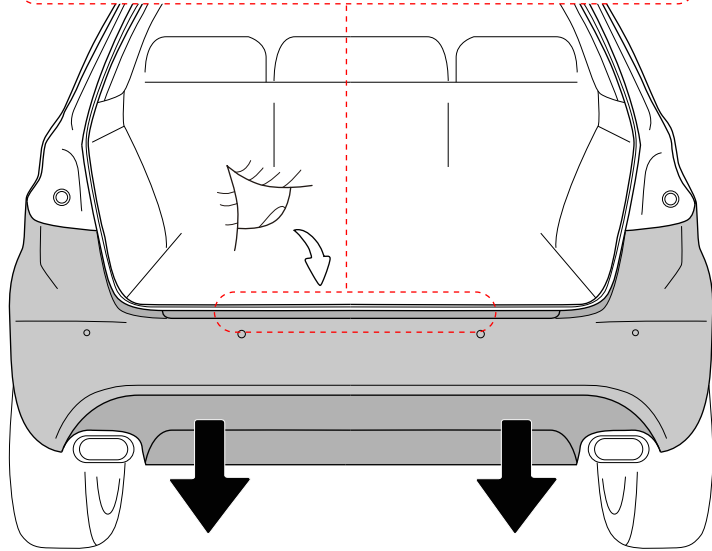
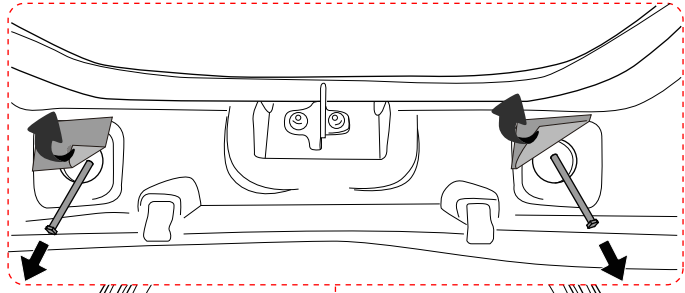
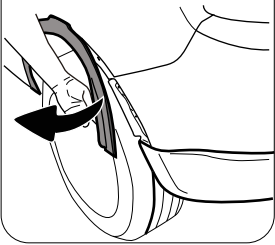

**MERCEDES  
GLA**

**INFINITI Q30**

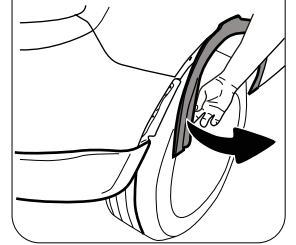

3

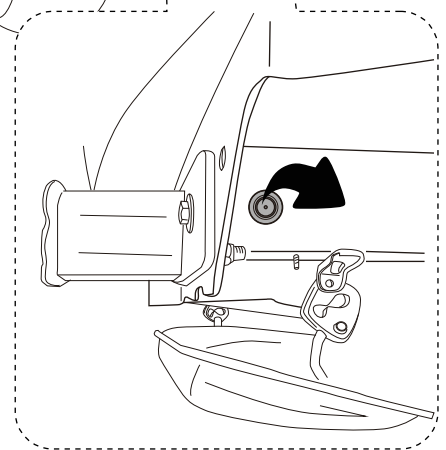
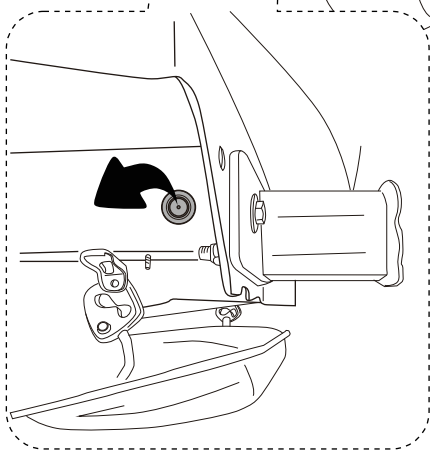
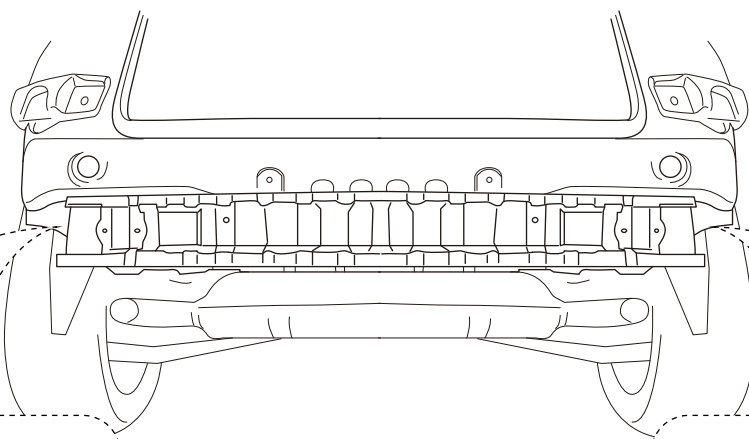

4

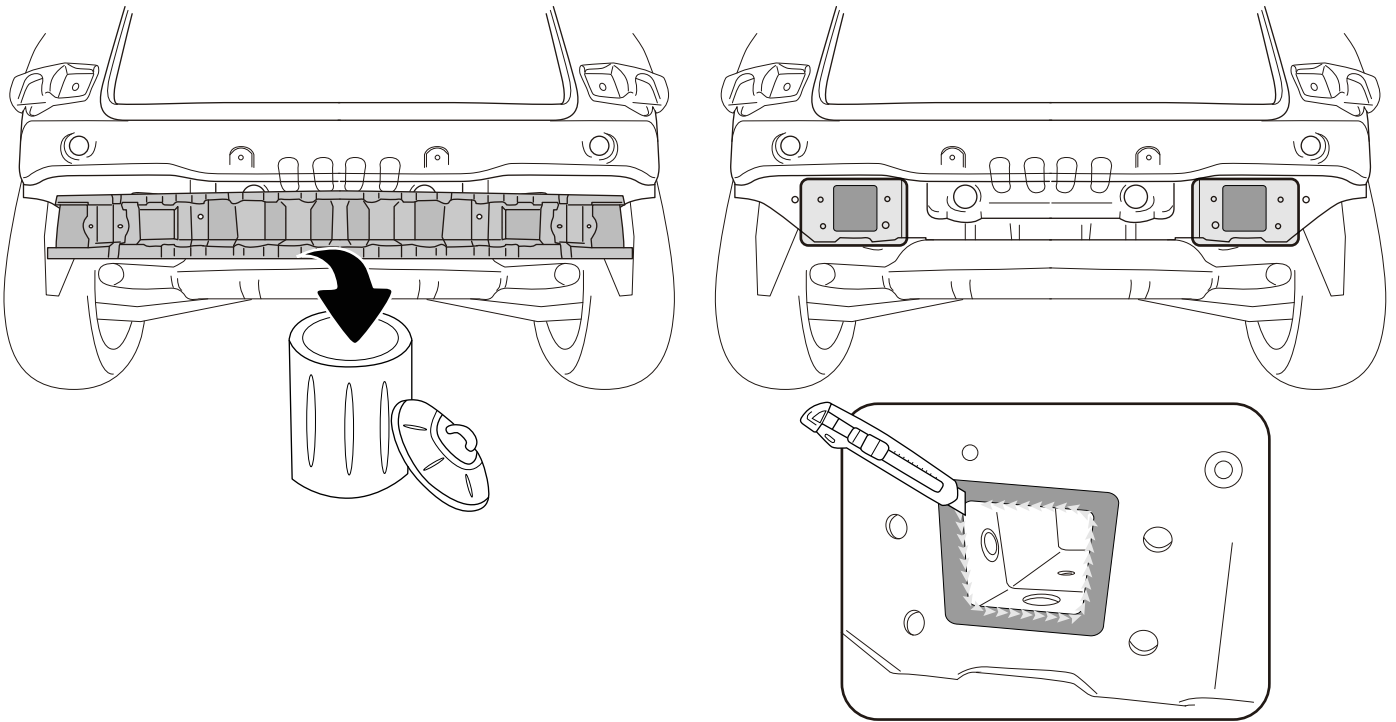

5

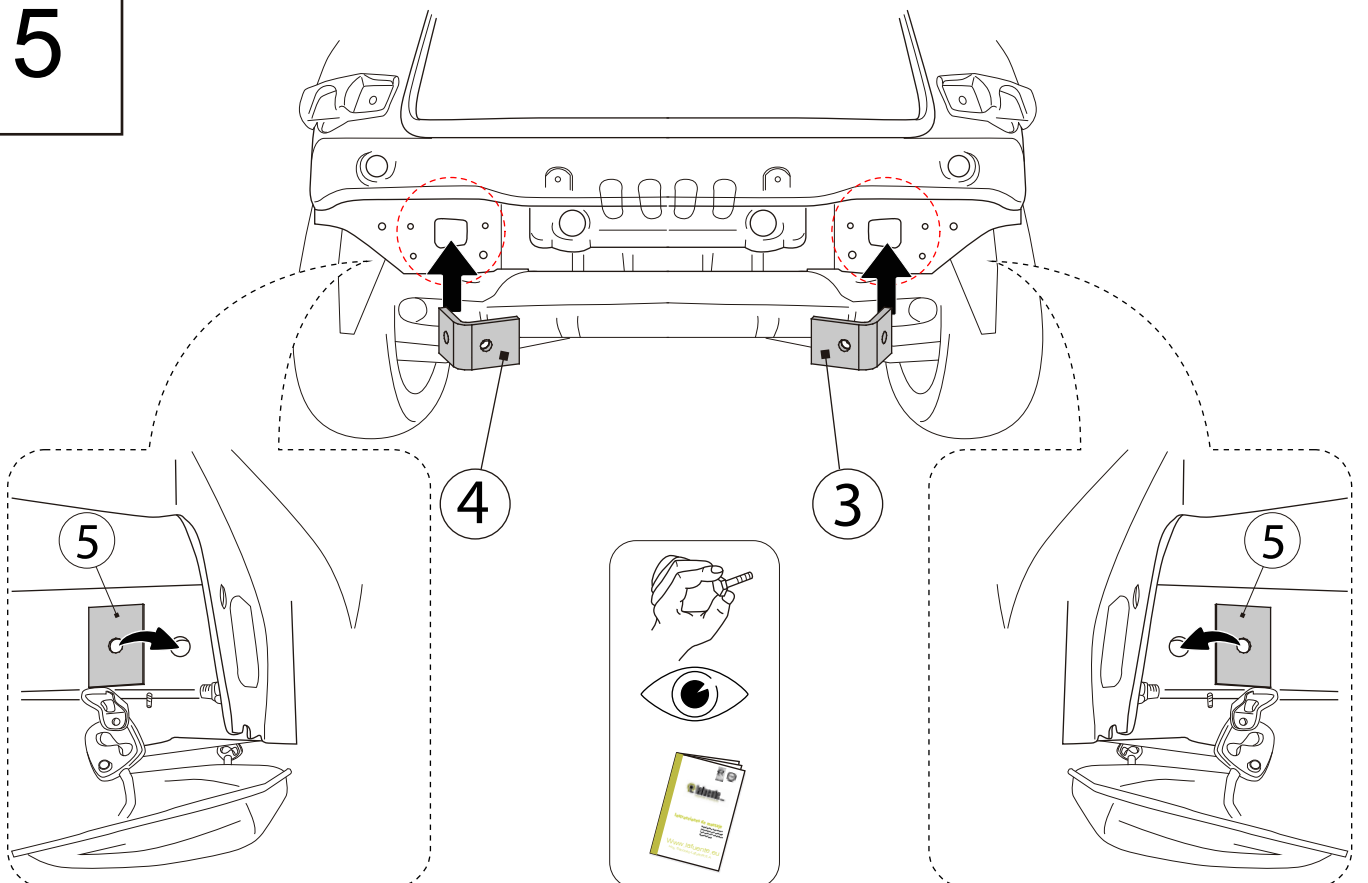

6



# MERCEDES CLA Shooting Brake

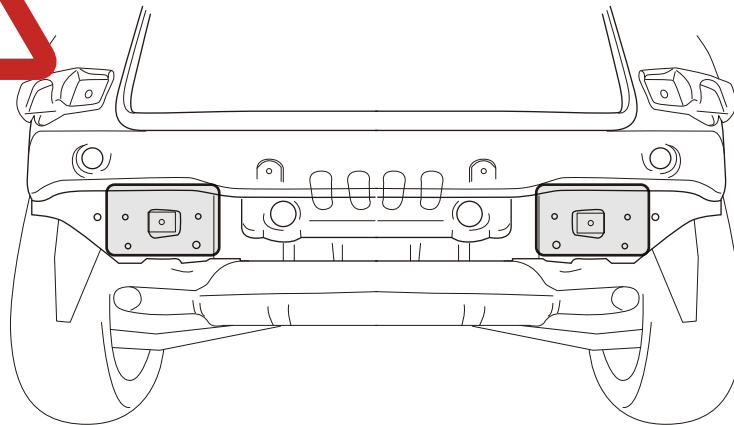

1º

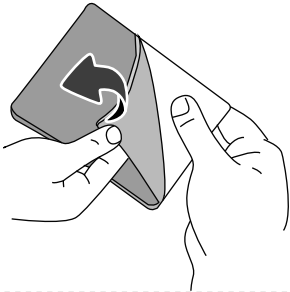

2º

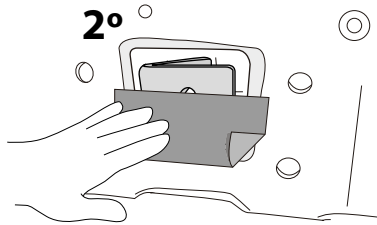

3º

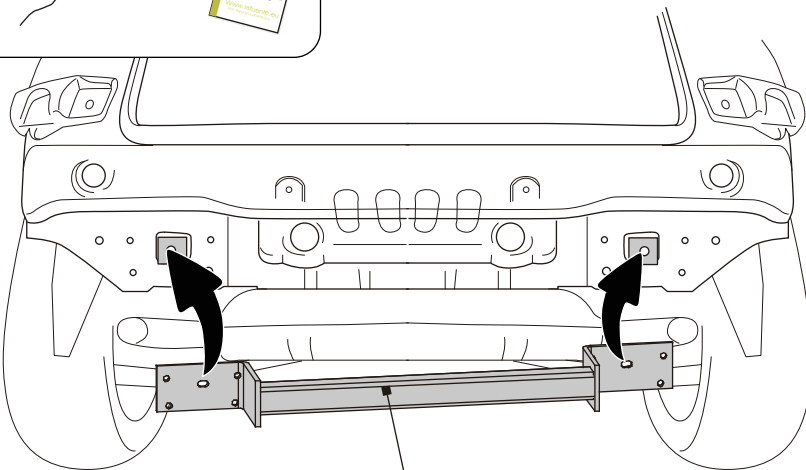
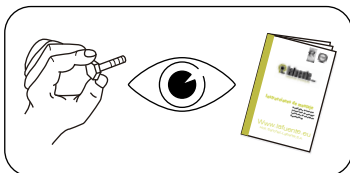
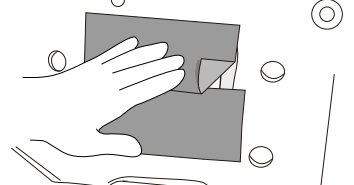

2

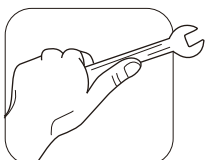
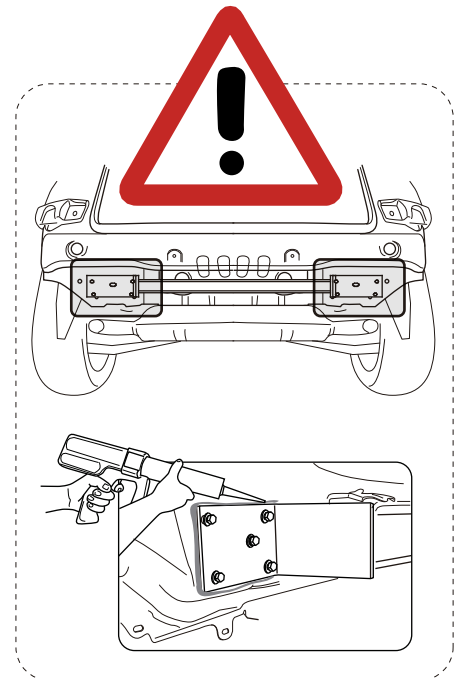

	M6	M8	M10	M12	M14	M16
8.8	10,4Nm	25,0Nm	51,0Nm	87,0Nm	140,0Nm	215,0Nm
10.9	15,5Nm	37,0Nm	75,0Nm	130,0Nm	205,0Nm	310,0Nm
12.9	18,0Nm	43,0Nm	87,0Nm	150,0Nm	240,0Nm	370,0Nm

7

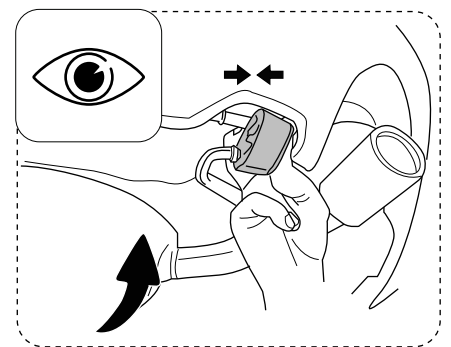
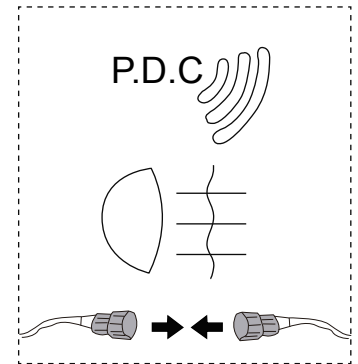
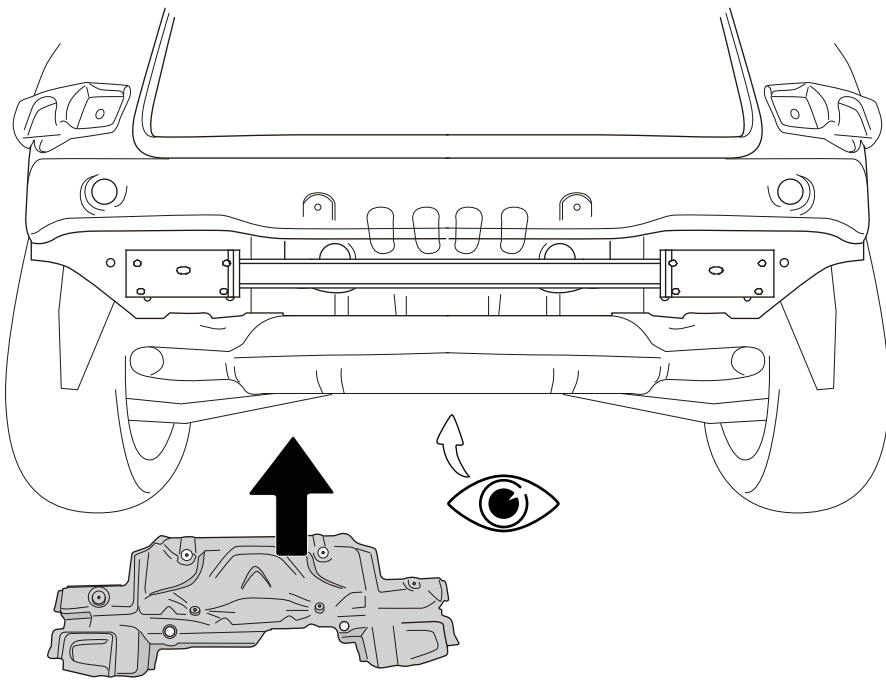

8



**MERCEDES  
GLA**

**MERCEDES  
GLA**

**INFINITI Q30**

**INFINITI Q30**

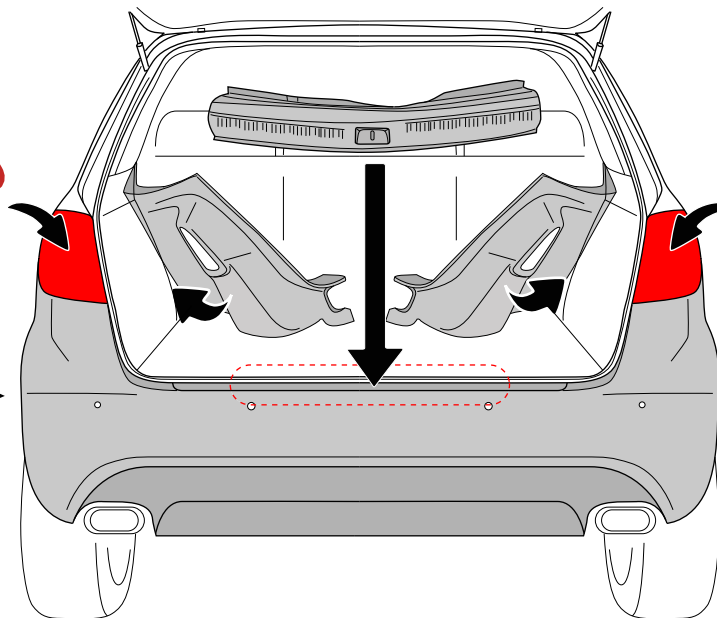
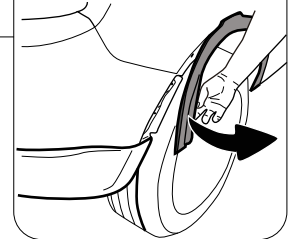
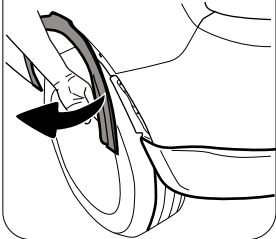

**MERCEDES  
CLA/CLA Shooting Brake**

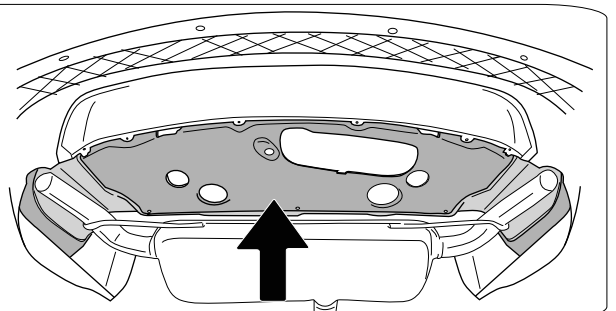

9



El corte es orientativo

unidades: mm

### MERCEDES CLA

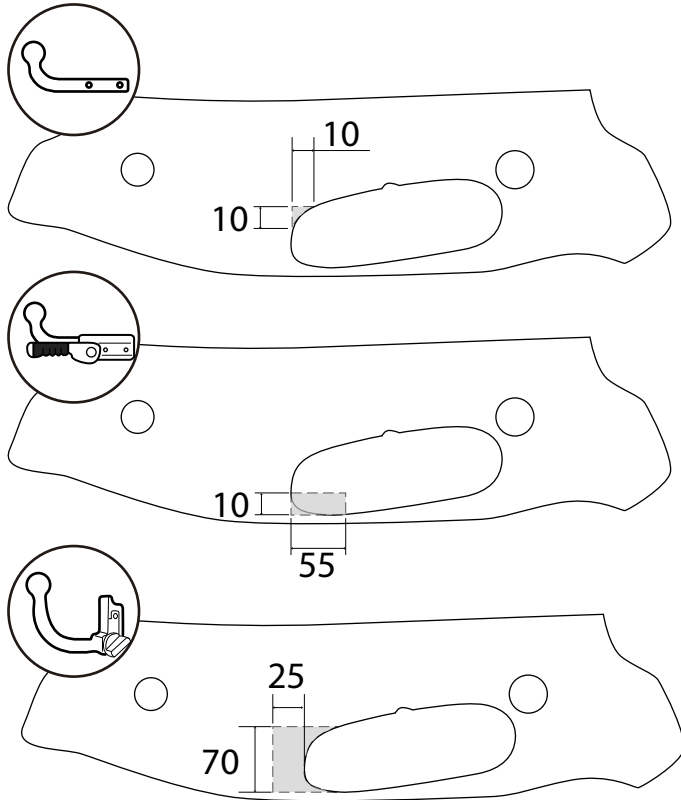

### MERCEDES CLA

Shooting Brake

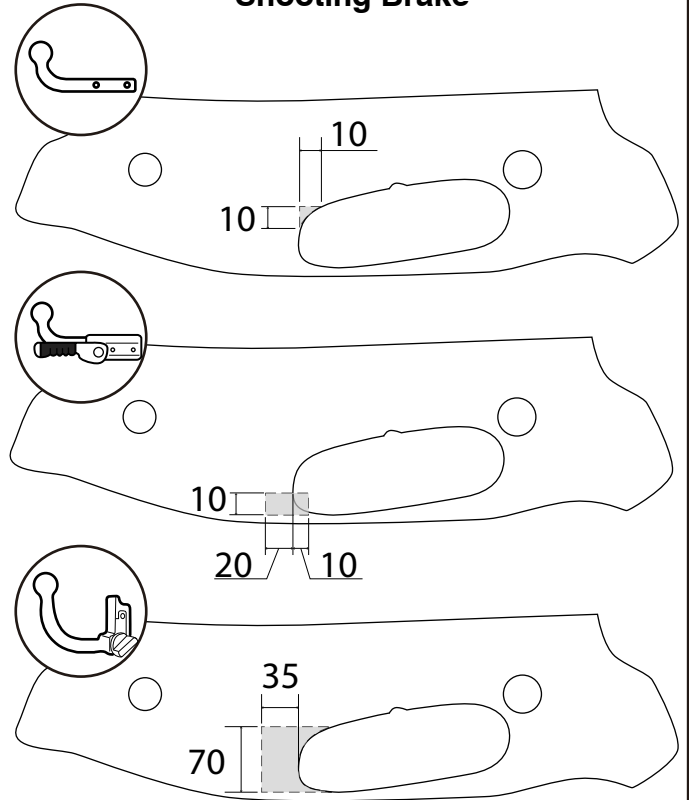

### MERCEDES CLASE A "URBAN"

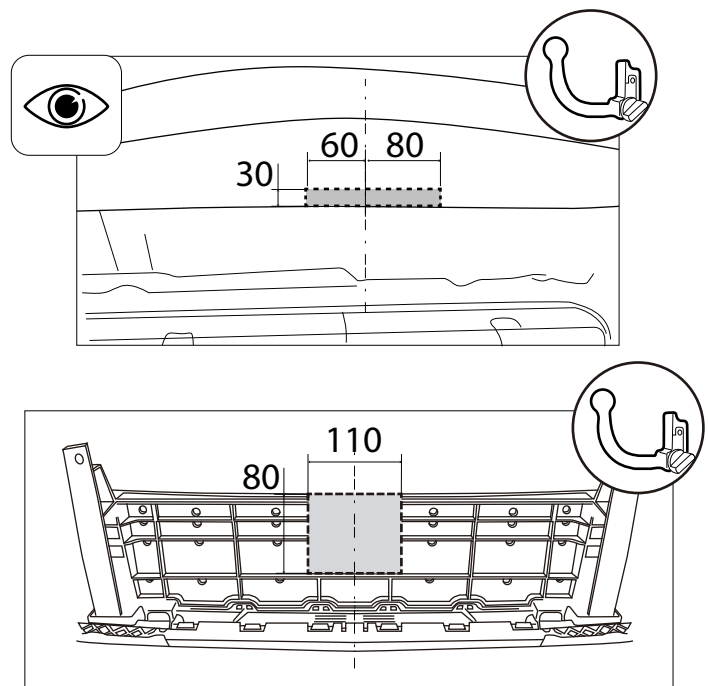
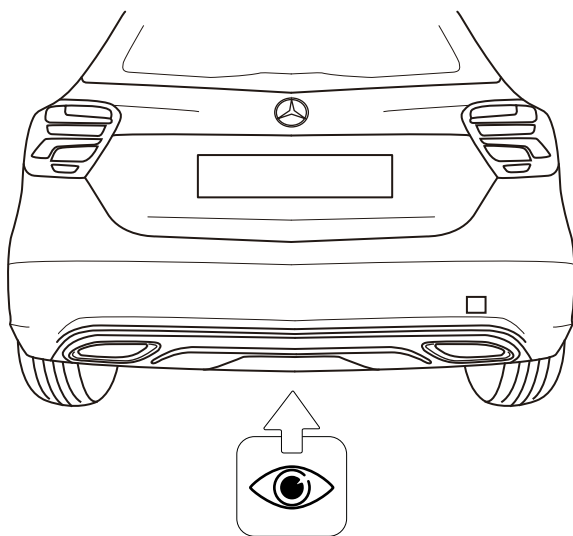



10



El corte es orientativo

unidades: mm

### INFINITI Q30

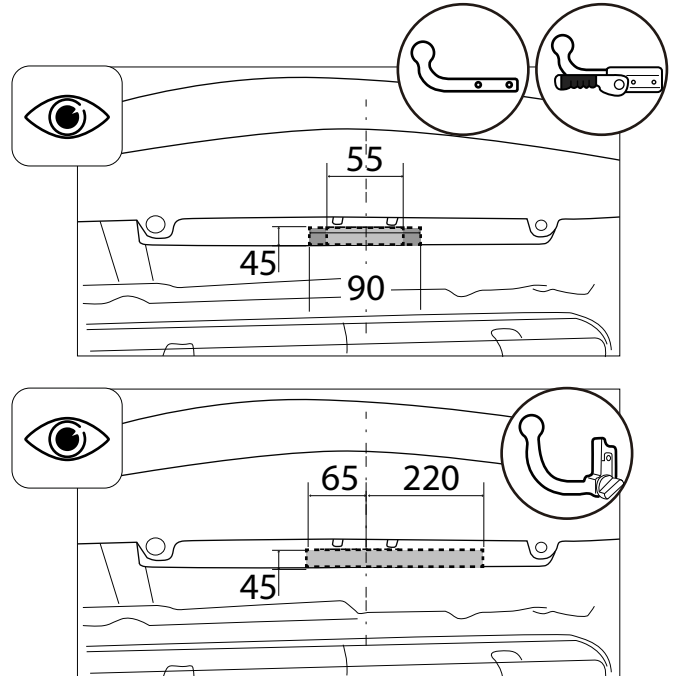
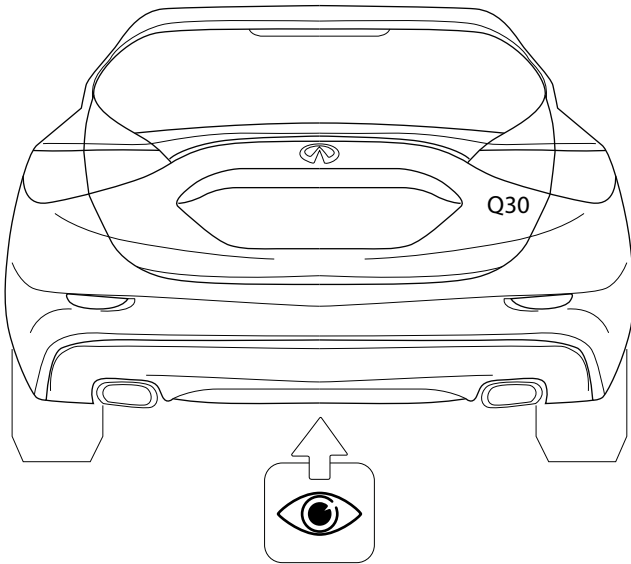

### INFINITI QX30

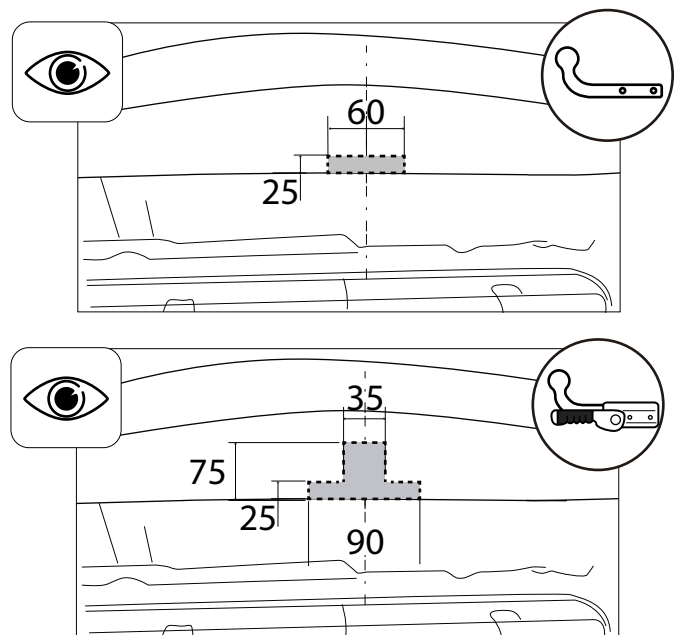
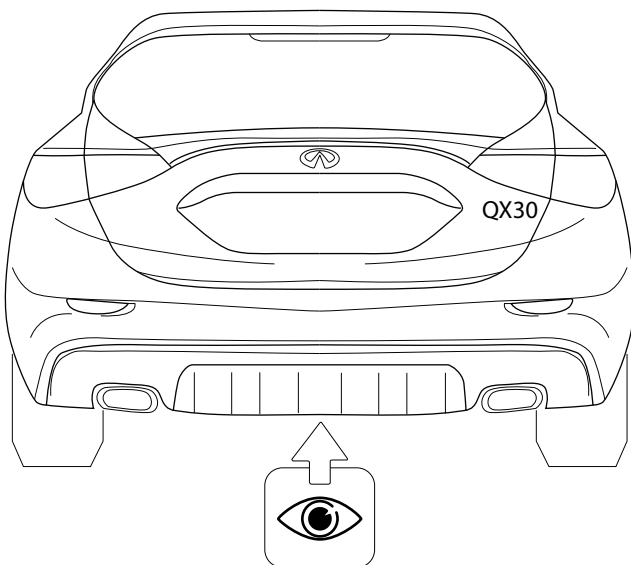

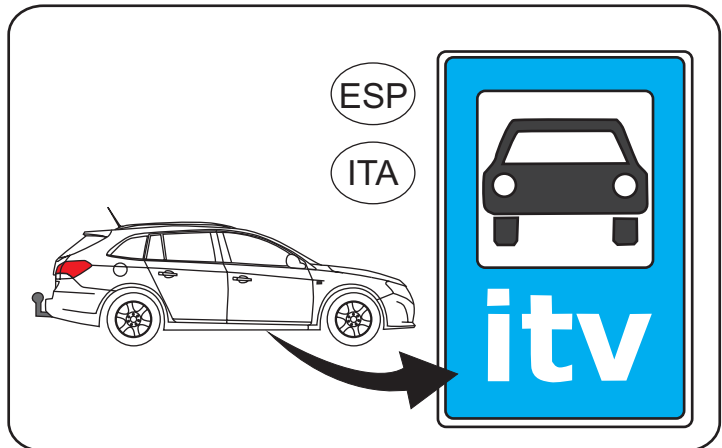
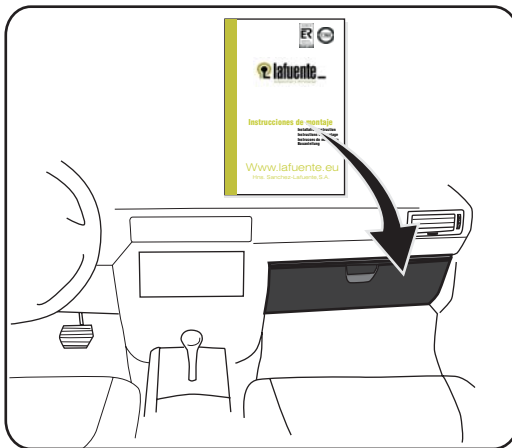
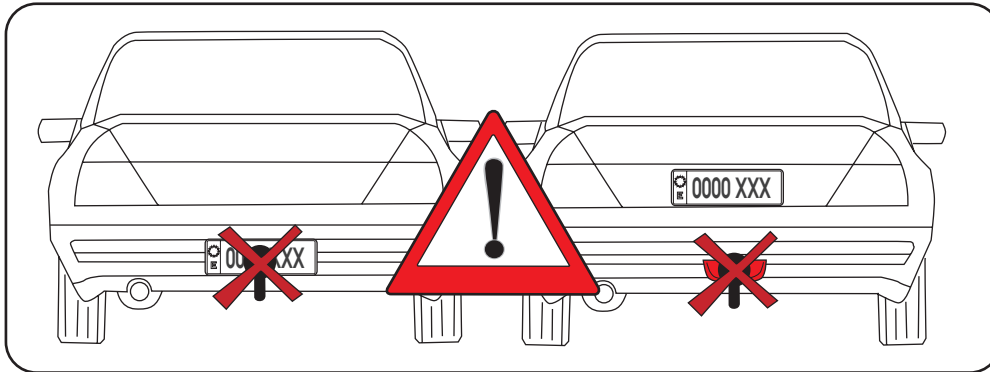
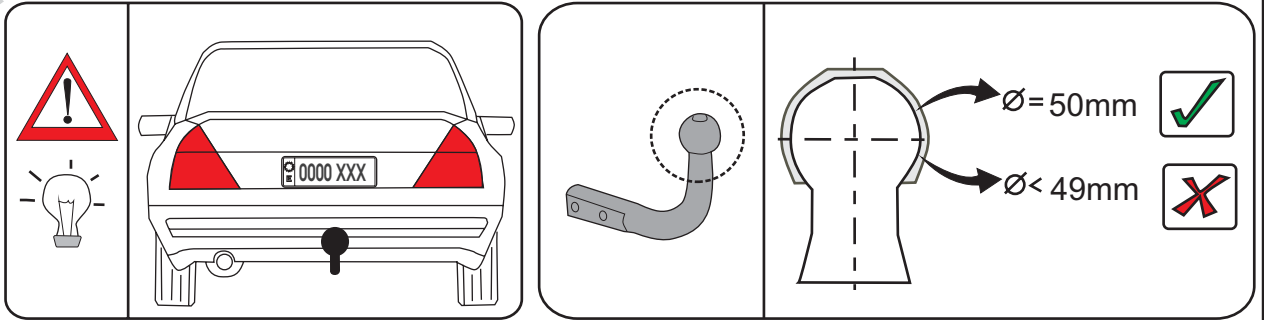
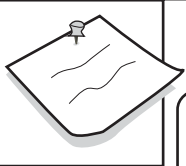

	M6	M8	M10	M12	M14	M16
8.8	10,4Nm	25,0Nm	51,0Nm	87,0Nm	140,0Nm	215,0Nm
10.9	15,5Nm	37,0Nm	75,0Nm	130,0Nm	205,0Nm	310,0Nm
12.9	18,0Nm	43,0Nm	87,0Nm	150,0Nm	240,0Nm	370,0Nm