

**CITROEN C5X (09/2021 - ...)**  
**PEUGEOT 408 (09/2022 - ...)**

M.M.R. 	S 	D
1701 kg.	105 kg.	9,70 kN



ECE R55

**ELEMENTOS DE UNIÓN / CONNECTION COMPONENTS / ELEMENTOS DE UNIÃO**  
**ÉLÉMENTS DE RACCORD / DAZUGEHÖRENDE TEILEN**

BOLA / BALL / BOLA/ ROTULE / KUGEL		VEHÍCULO / VEHICLE / VEÍCULO / VÉHICULE / FAHRZEUG	
		c  6 x M12x40 DIN 933	8.8
a	2 x M12x65 DIN 931	8.8	d  4 x M12 DIN 985
b	2 x M12 DIN 985	8	e  2 x M12 DIN 6798
			f  2 x M12 DIN 9021
		a	4 x M12x25 DIN 933
		b	4 x M12 DIN 125
		a	4 x M12x 25 DIN 933
		b	4 x M12 DIN 127
		w	1 x M10x30 DIN 933
		x	1 x M10 DIN 985
		y	2 x M10 DIN 125
		z	1 x M10 DIN 2093

Par de apriete para los tornillos/Tightening torque for bolts/Binário de aperto para os parafusos/  
 Couple de serrage pour vis/Schrauben Drehmoment

Und.Nm	M6		M8		M10		M12		M14		M16
	1	1,25	1,5	1,25	1,75	1,5	1,25	1,75	1,5	2	
8.8	11,3	27,3	54,0	57,0	93,0	97,0	101,0	148,0	159,0	230,0	
10.9	16,5	40,1	79,0	83,0	137,0	143,0	149,0	218,0	234,0	320,0	
12.9	19,3	46,9	93,0	98,0	160,0	167,0	174,0	255,0	274,0	395,0	

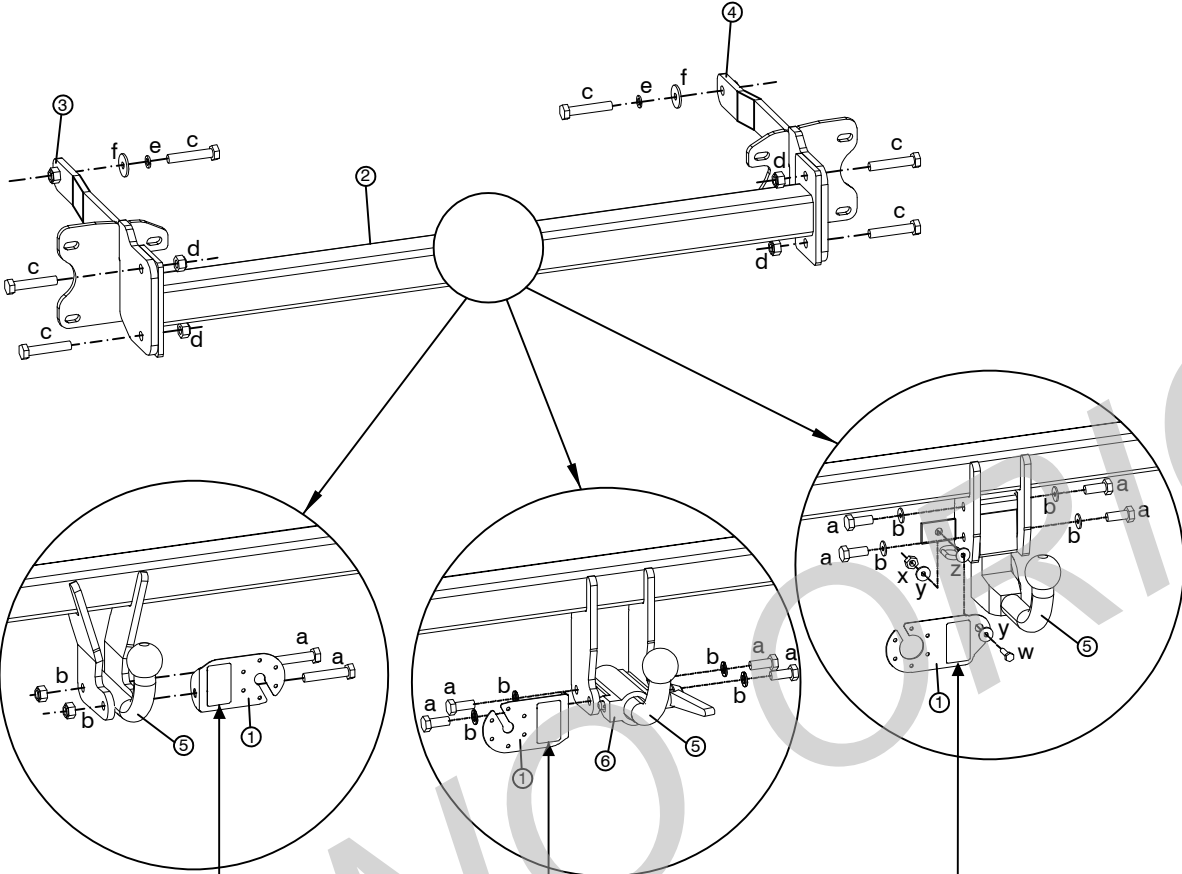

Made by LAFUENTE (SPAIN)  
 Tlf. (+34) 952 625 840  
 www.lafuente.eu

**Eg** 55R -02 2761

TIPO EE0659 D 9,70 kN  
 CLASE A-50X S 105 kg

Made by LAFUENTE (SPAIN)  
 Tlf. (+34) 952 625 840  
 www.lafuente.eu

**Eg** 55R -02 2762

TIPO EE1659 D 9,70 kN  
 CLASE A-50X S 105 kg

Made by LAFUENTE (SPAIN)  
 Tlf. (+34) 952 625 840  
 www.lafuente.eu

**Eg** 55R -02 2763

TIPO EE4659 D 9,70 kN  
 CLASE A-50X S 105 kg

E9\*55R02/02\*2761\*00

E9\*55R02/02\*2762\*00

E9\*55R02/02\*2763\*00

Este documento debe ser presentado en la I.T.V. junto con el certificado de montaje.  
 Comprobar en el Certificado de Conformidad (COC) del vehículo las capacidades máximas de arrastre y carga vertical.  
 Check the vehicle's documentation for the maximum towing and vertical load capacities.  
 Verificar no Certificado de Conformidade do veículo as capacidades máximas de reboque e carga vertical.  
 Consultez la carte grise du véhicule pour connaître les capacités maximales de remorquage et de charge verticale.  
 Überprüfen Sie die Fahrzeugdokumentation auf die maximale Anhängelast und Stützlast.

HERMANOS SÁNCHEZ-LAFUENTE, S.A.  
 No asume ningún tipo de responsabilidad por daños causados por usos inadecuados.  
 Assumes no responsibility for damage caused by misuse.  
 Não assume qualquer responsabilidade por danos causados por utilização indevida.  
 Decline toute responsabilité en cas de dommages causés par une mauvaise utilisation.  
 Übernimmt keine Verantwortung für Schäden, die durch Missbrauch verursacht werden.





**CITROEN C5X** (09/2021 - ...)

**PEUGEOT 408** (09/2022 - ...)



EE0659



EE1659



EE4659

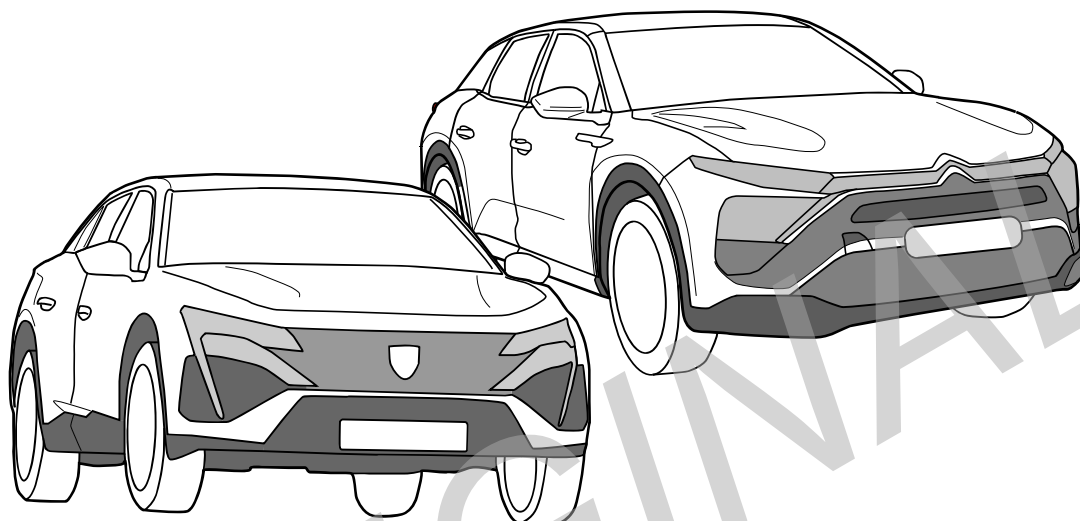

Instrucciones de montaje - Installation instructions - Instruções de montagem - Notice de montage - Montageanleitung

1

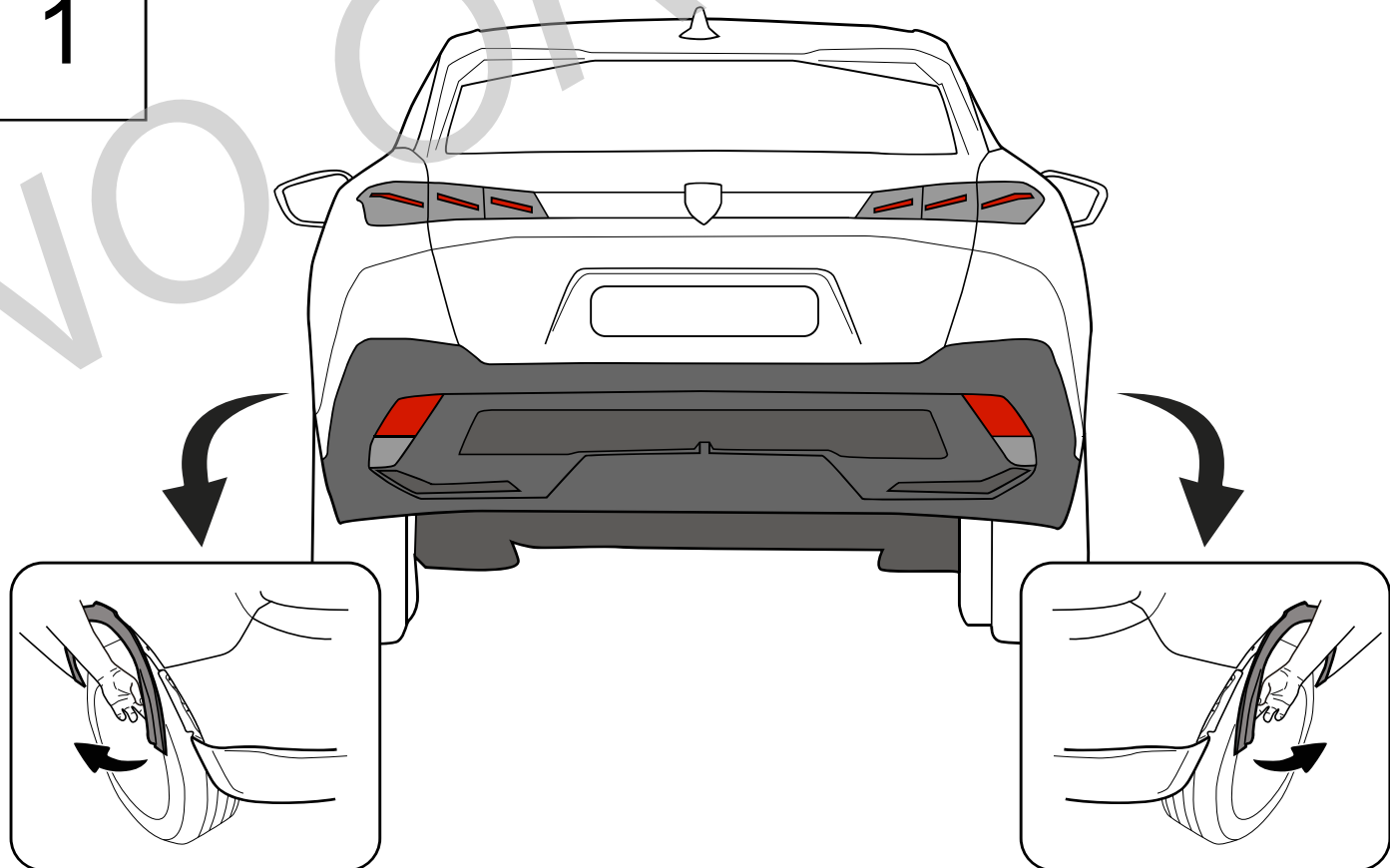

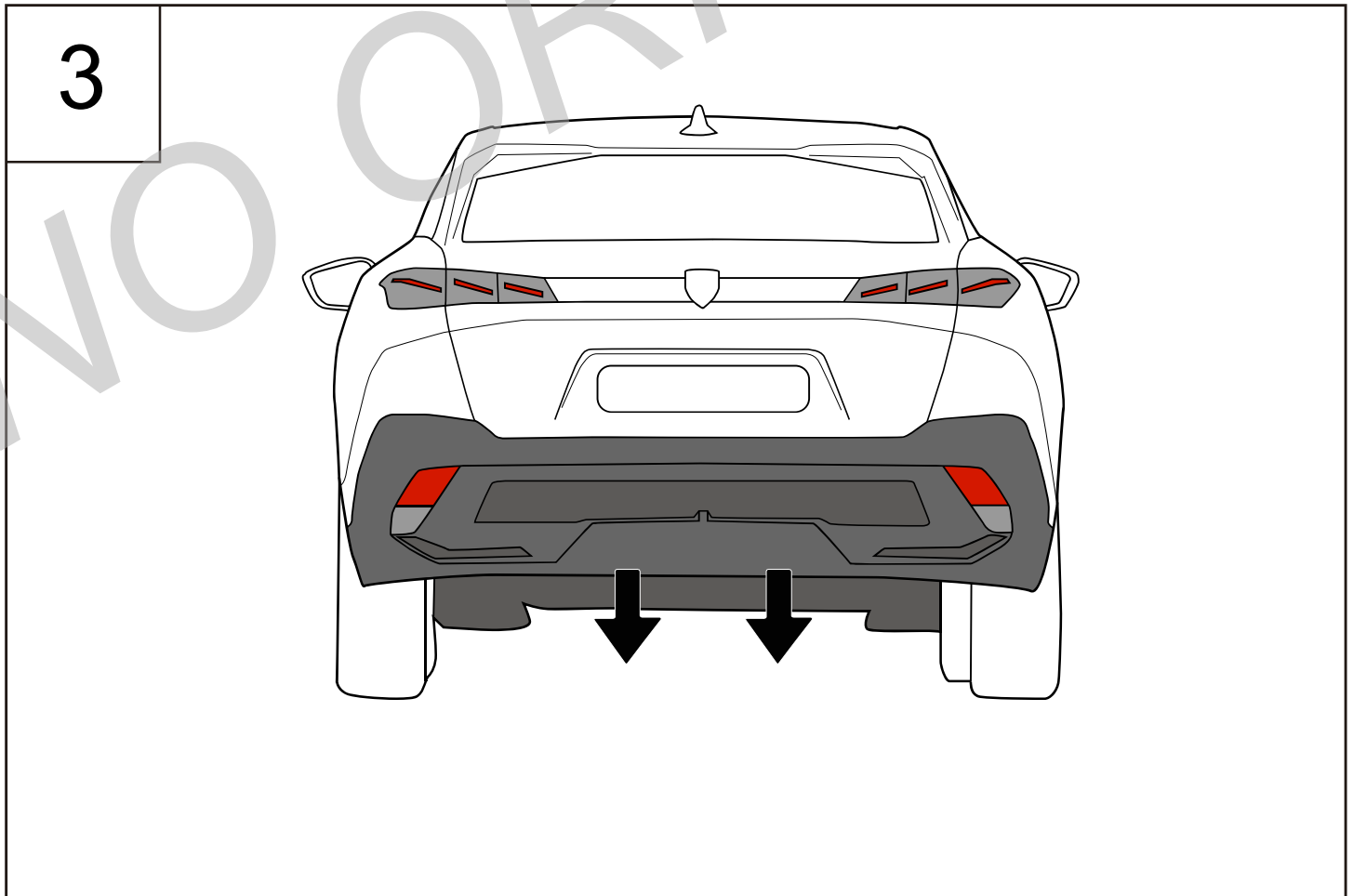
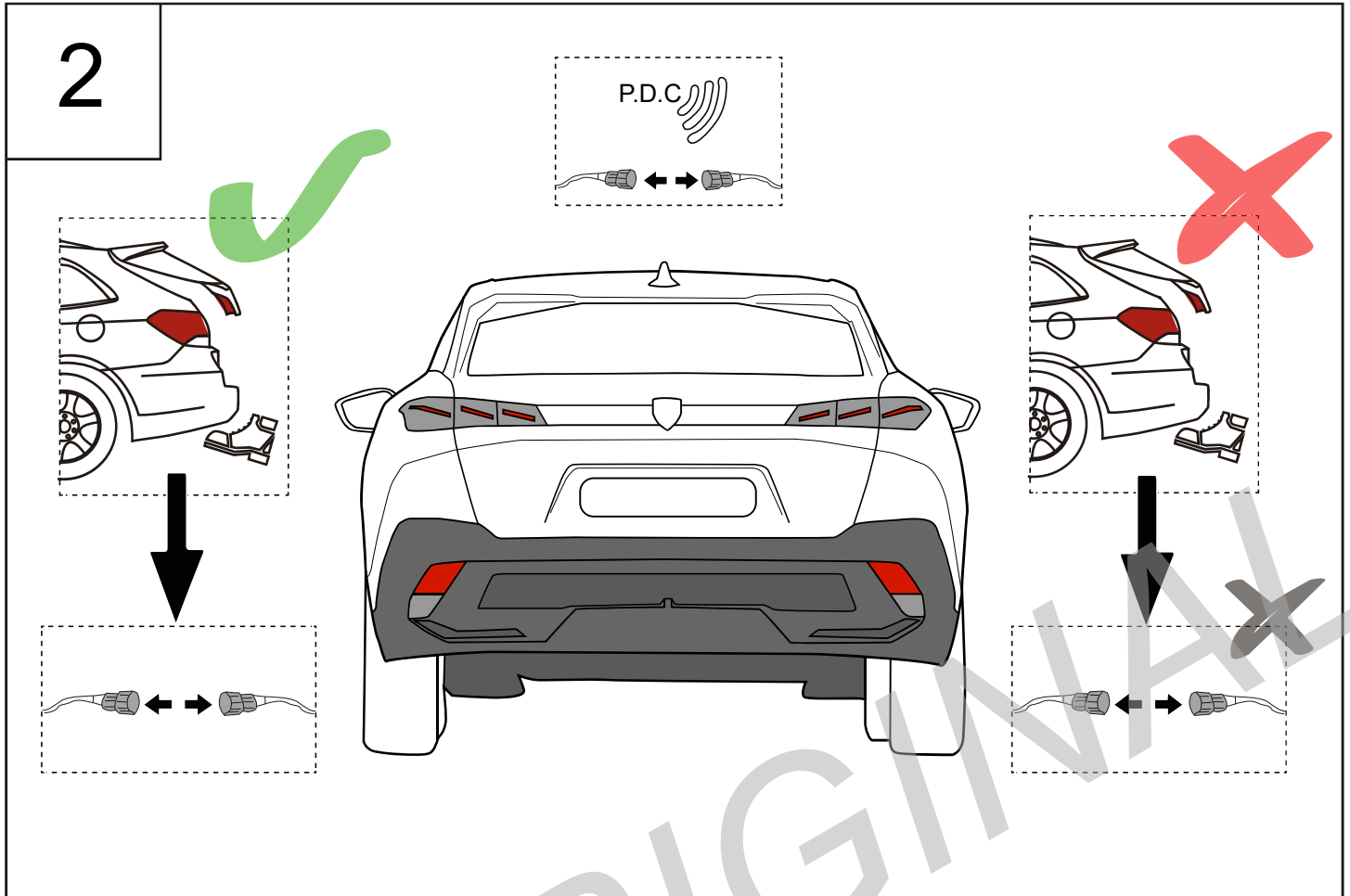

4

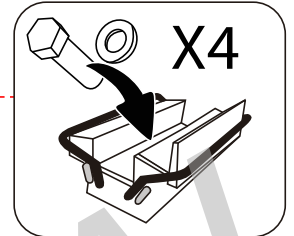
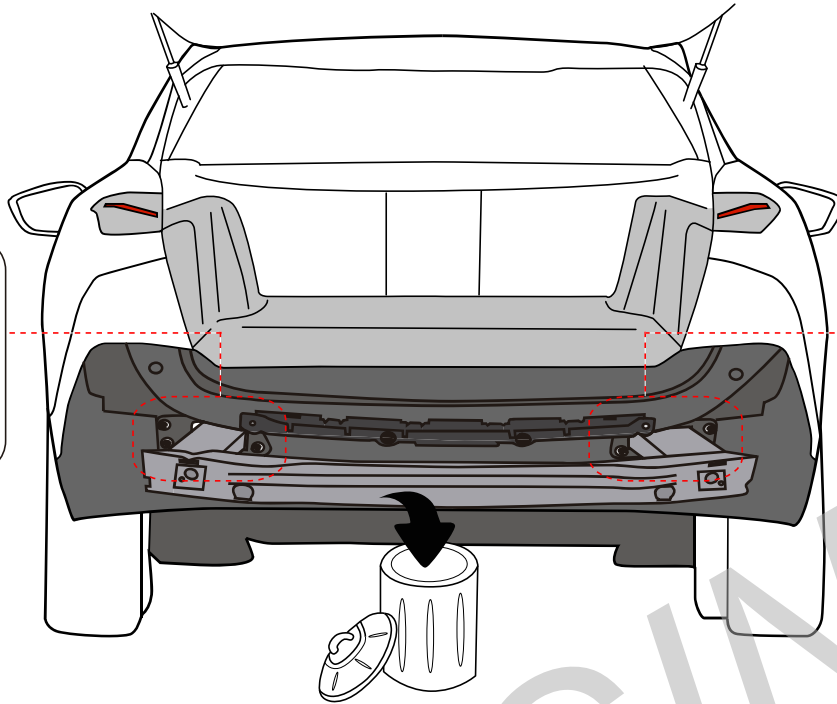
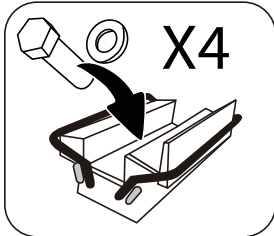

5

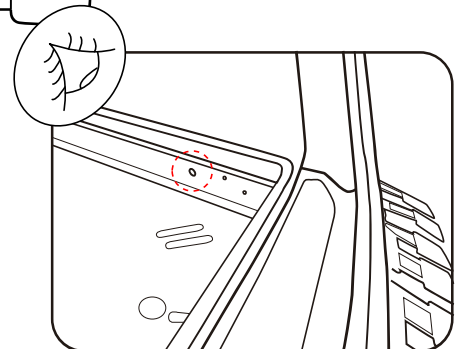
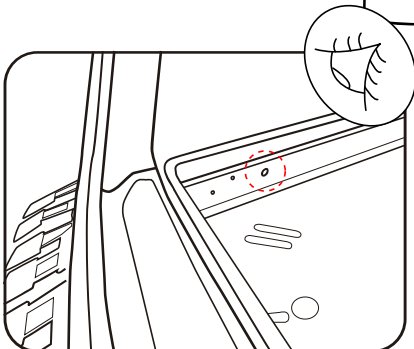
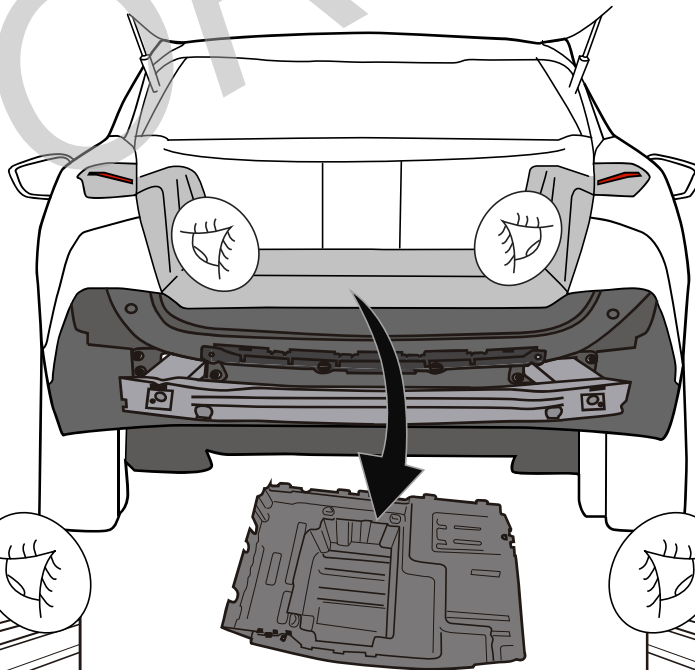

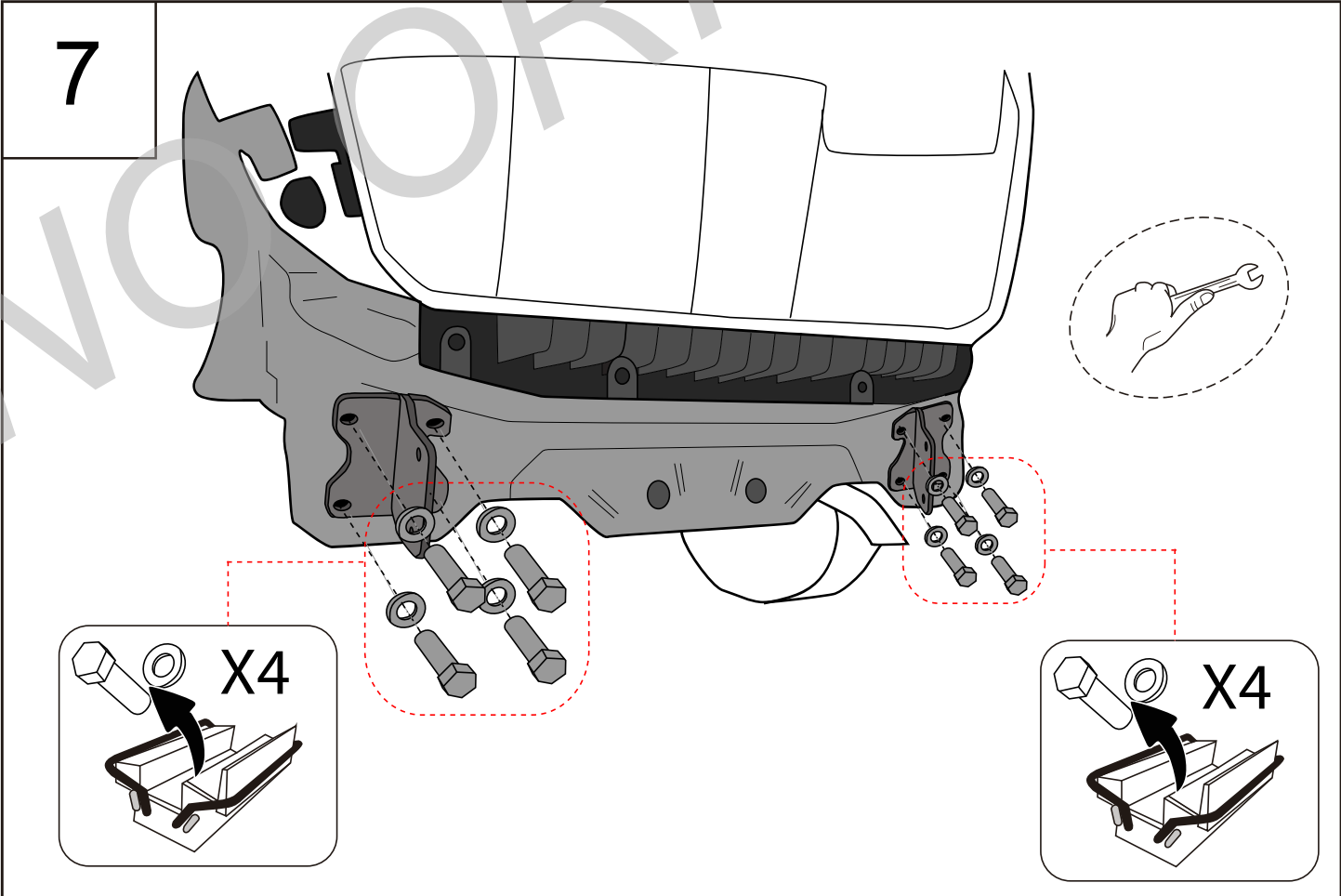
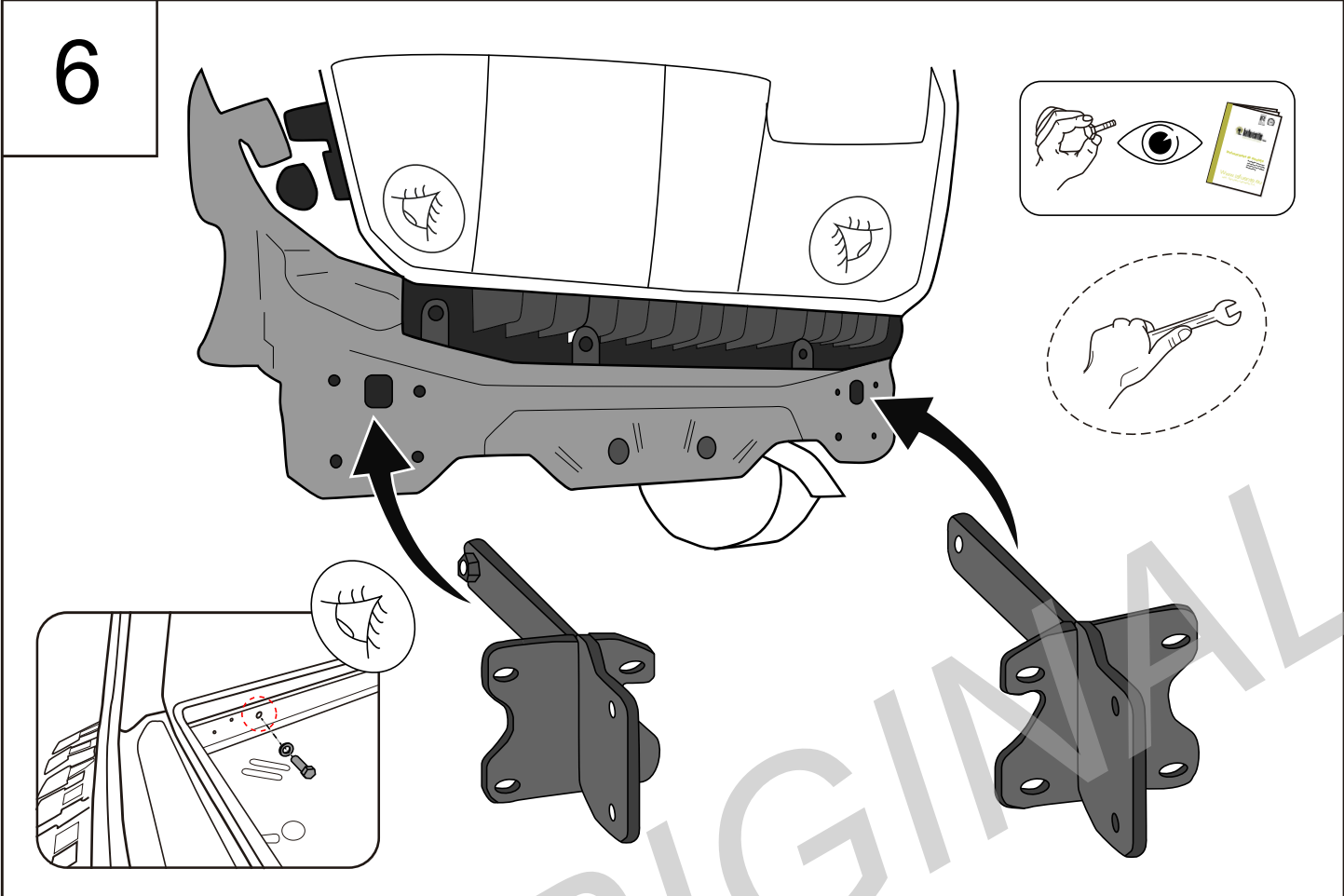

8

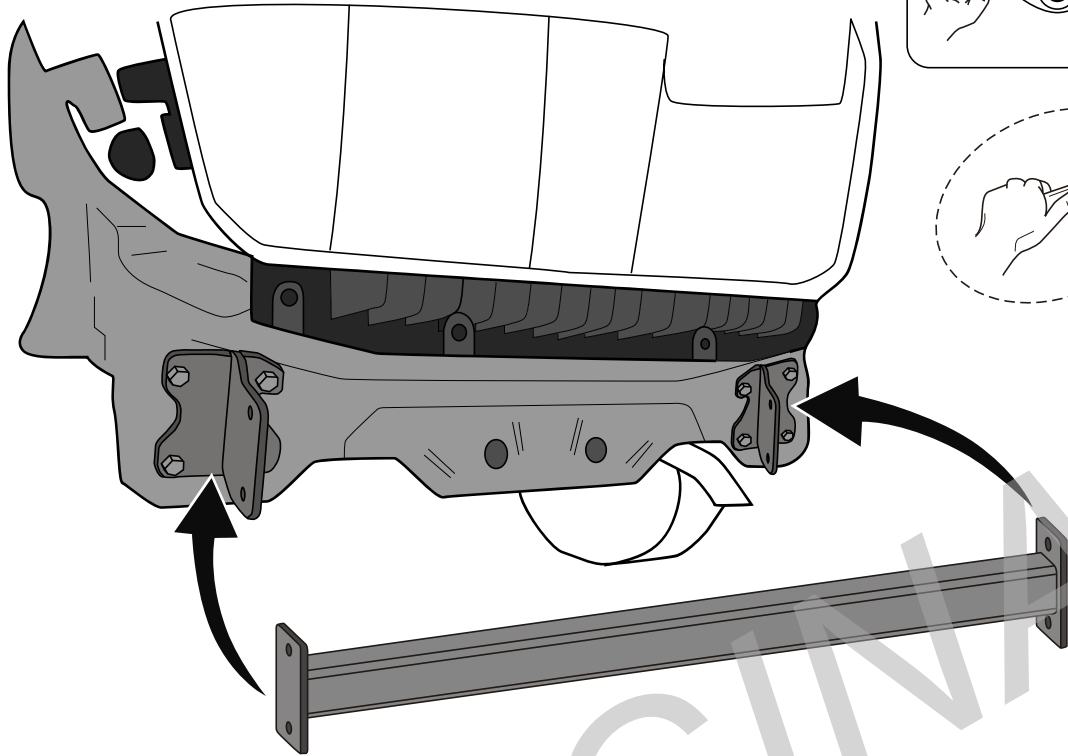

9

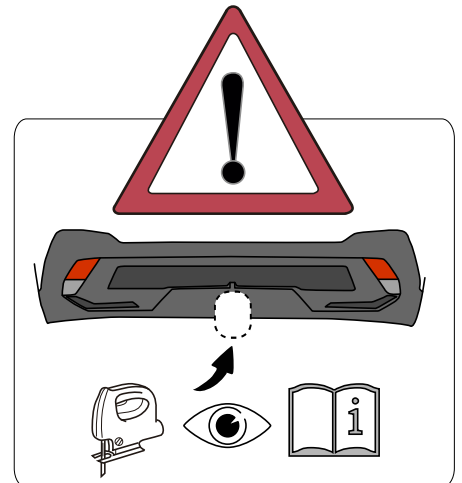
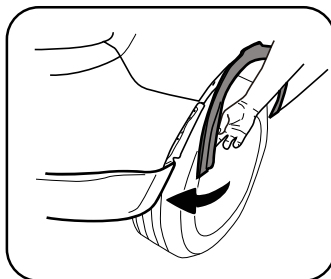
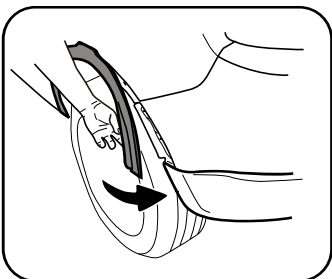
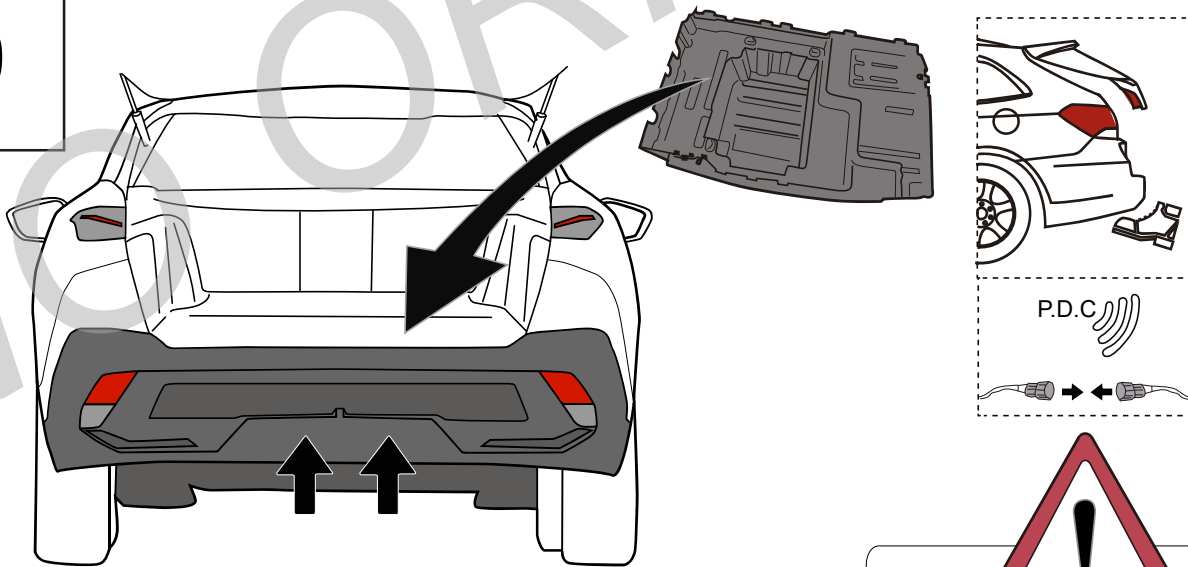

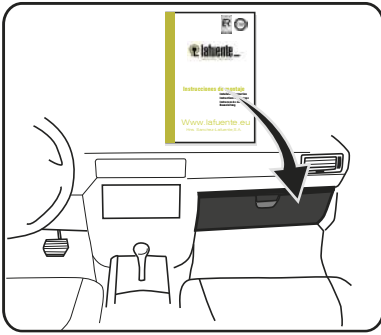

	M6	M8	M10	M12	M14	M16
8.8	10,4Nm	25,0Nm	51,0Nm	87,0Nm	140,0Nm	215,0Nm
10.9	15,5Nm	37,0Nm	75,0Nm	130,0Nm	205,0Nm	310,0Nm
12.9	18,0Nm	43,0Nm	87,0Nm	150,0Nm	240,0Nm	370,0Nm

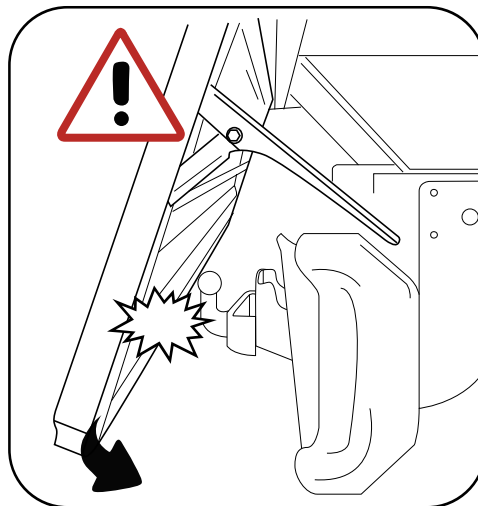
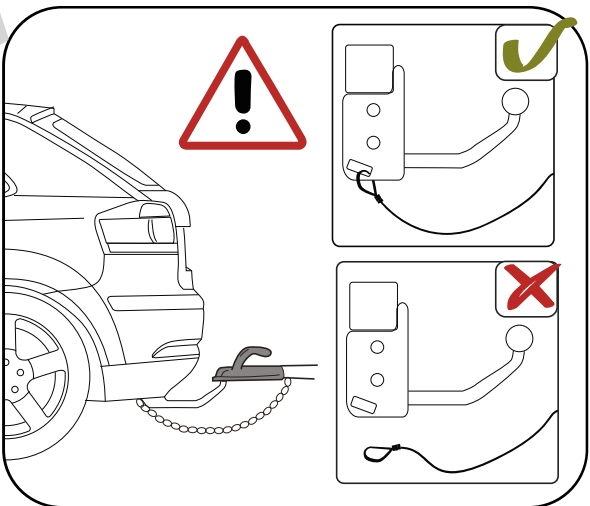
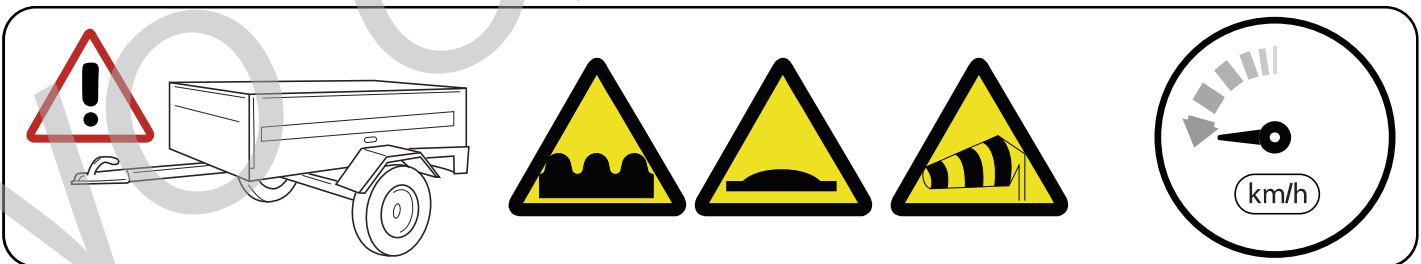
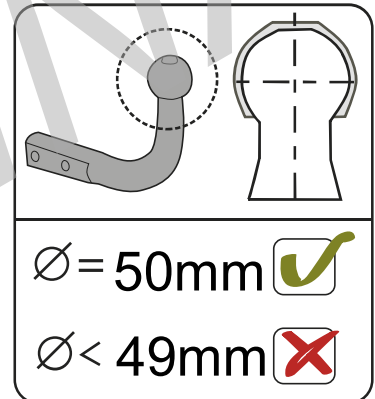
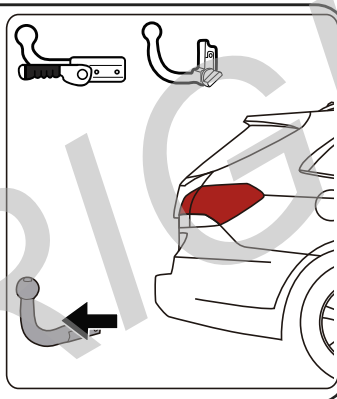
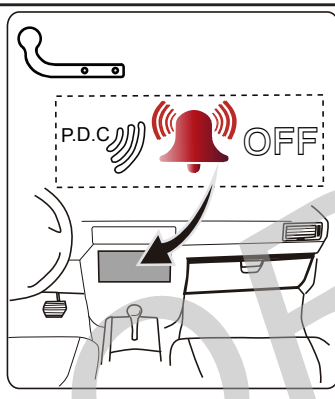
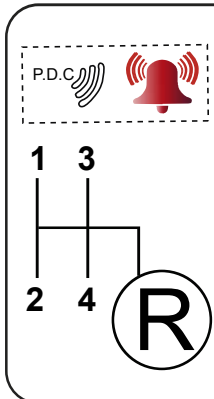
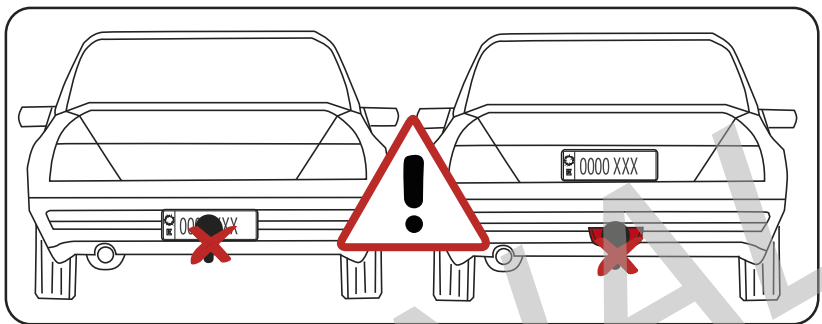
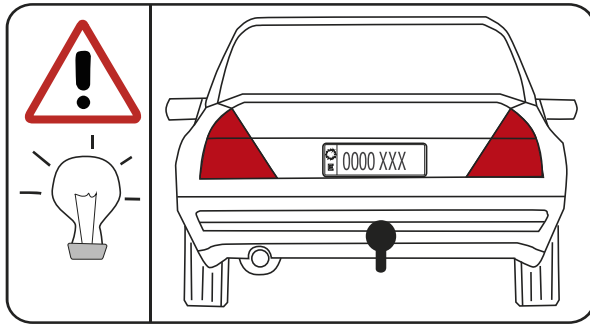



EE0659

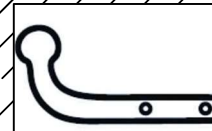

EE1659

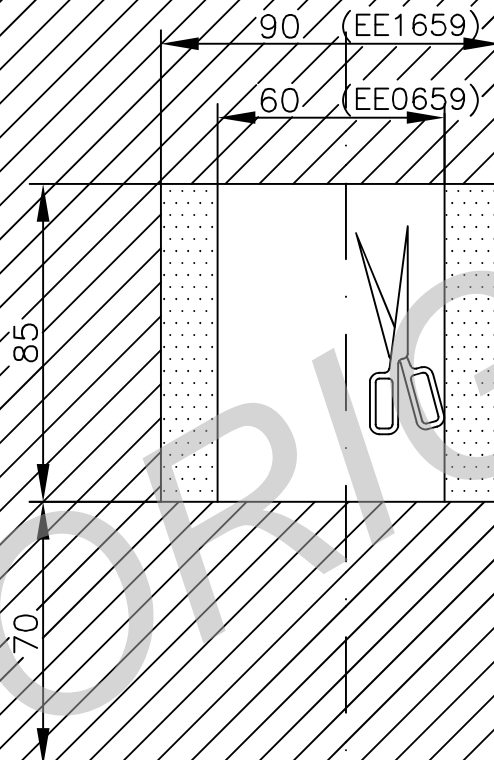

ESP: El corte es orientativo puede variar por modelo y año  
UK: The cut is indicative it can change for model and year  
PT: O corte é inidcativo. Pode variar segundo o modelo e ano.  
FR: La decoupe est indicative et peut varier selon le modèle et l'année  
DE: Der Schnitt ist indikativ, er kann je nach Modell und Jahr variieren



CITROEN C5X

1:2

mm

EE0659-EE1659

Rev.  
P1





EE4659

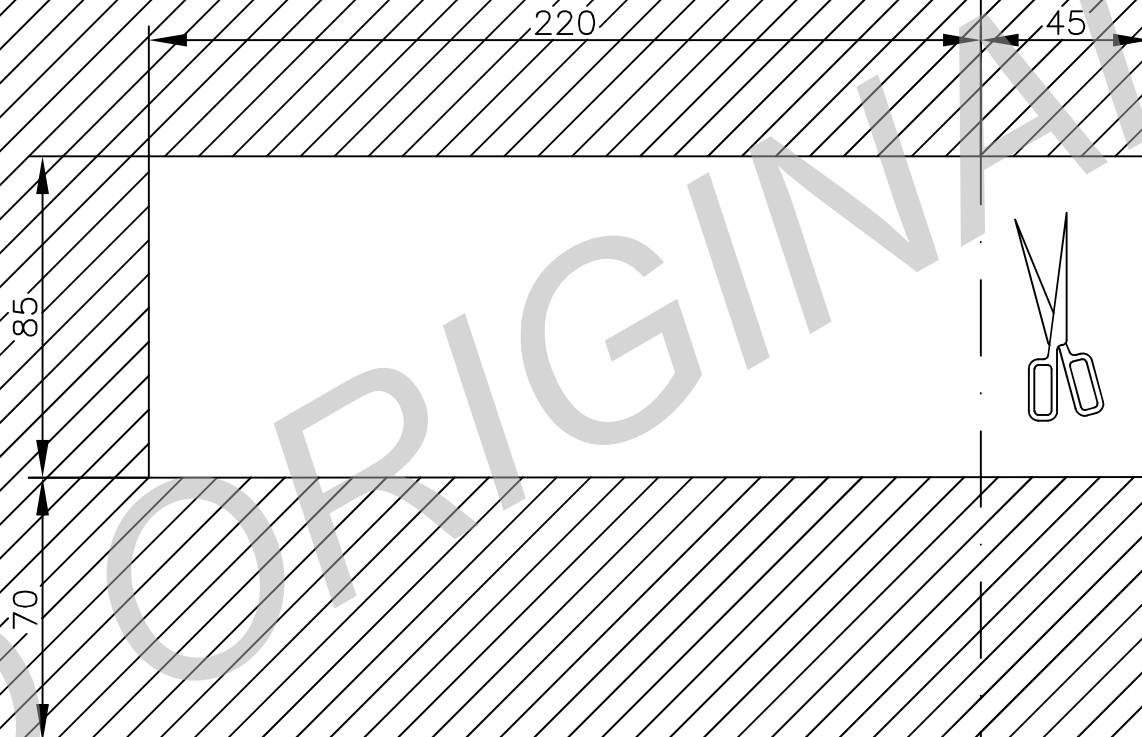
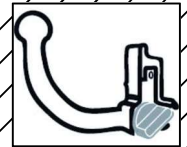

ESP: El corte es orientativo puede variar por modelo y año  
UK: The cut is indicative it can change for model and year  
PT: O corte é inidcativo. Pode variar segundo o modelo e ano.  
FR: La decoupe est indicative et peut varier selon le modèle et l'année  
DE: Der Schnitt ist indikativ, er kann je nach Modell und Jahr variieren



CITROEN C5X

1:2

mm

EE4659

Rev.  
P1

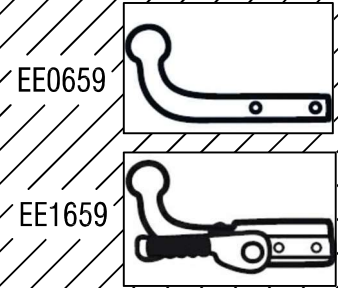
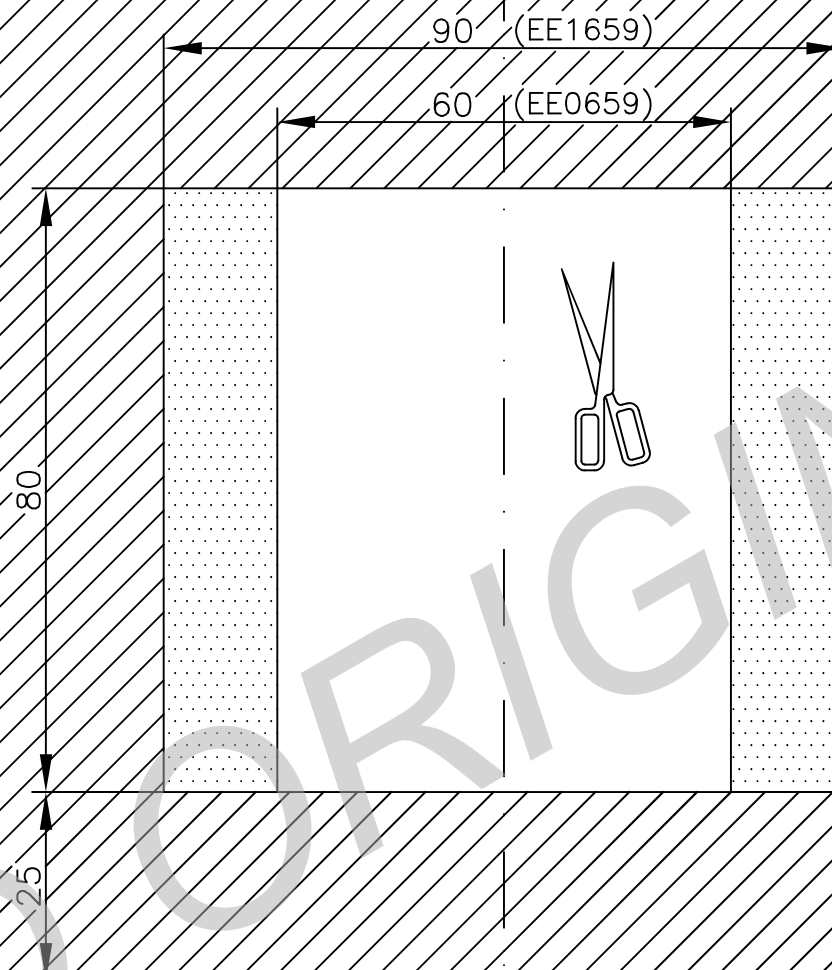

ESP: El corte es orientativo puede variar por modelo y año  
UK: The cut is indicative it can change for model and year  
PT: O corte é inidcativo. Pode variar segundo o modelo e ano.  
FR: La decoupe est indicative et peut varier selon le modèle et l'année  
DE: Der Schnitt ist indikativ, er kann je nach Modell und Jahr variieren



		PEUGEOT 408	
1:1	mm	EE0659-EE1659	Rev. P1



EE4659

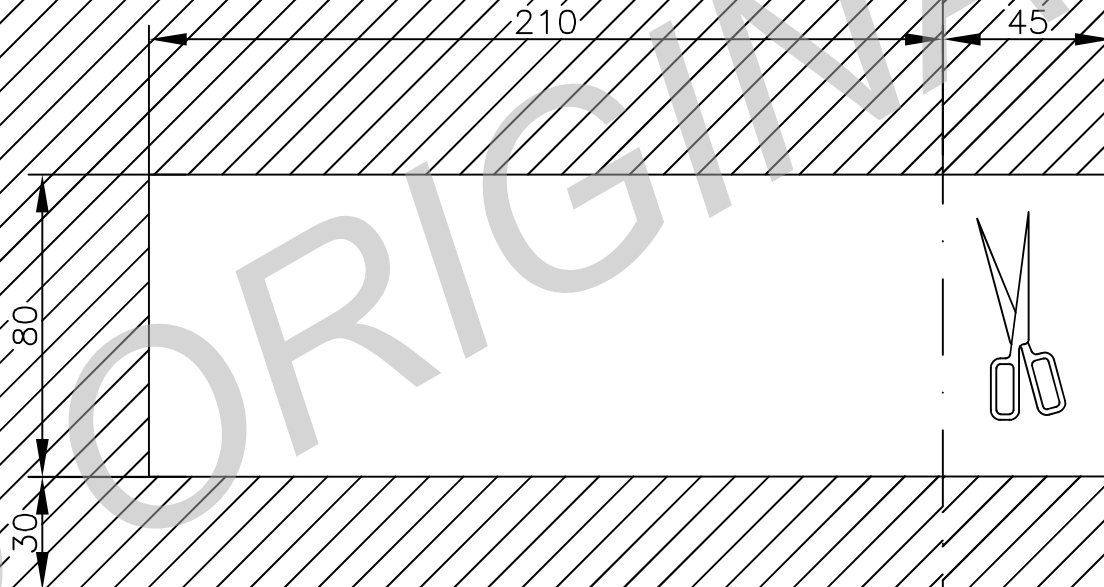
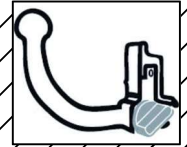

ESP: El corte es orientativo puede variar por modelo y año  
UK: The cut is indicative it can change for model and year  
PT: O corte é inidcativo. Pode variar segundo o modelo e ano.  
FR: La decoupe est indicative et peut varier selon le modèle et l'année  
DE: Der Schnitt ist indikativ, er kann je nach Modell und Jahr variieren



 lafuenta®

PEUGEOT 408

1:2

mm

EE4659

Rev.  
P1